



LIFE OUTSIDE THE LINES

**CONTRACT DOCUMENTS AND
SPECIFICATIONS**

**2024 CONCRETE REPLACEMENT AND
PAVING PROGRAM**

Bid 24-03

**City of Grain Valley
Community Development Department
711 S. Main Street
Grain Valley, MO 64029**

**Bidder's Name and Address:
Phone & Fax No.**

January 2024

TABLE OF CONTENTS

CONTRACT DOCUMENTS AND SPECIFICATION

2024 CONCRETE REPLACEMENT AND PAVING PROGRAM

CITY OF GRAIN VALLEY, MO

SUBJECT	PAGE TO PAGE (INCLUSIVE)
Advertisement to Bid	A-1 : A-2
Instructions to Bidders	IB-1 : IB-8
Missouri E-Verify Affidavit	EV-1 : EV-2
Bidders Affidavit	BA-1 : BA-2
Bid Form	BF-1 : BF-6
Bid Requirements	BR-1 : BR-2
Bid Bond Form	BB-1 : BB-2
Bid Guaranty	BG-1
Notice of Award	NA-1
Missouri Domestic Products Procurement Law Agreement (Unit Price)	MO-PR-1 AUP-1 : AUP-5
Performance Bond	PEB-1 : PEB-2
Payment Bond	PAB-1 : PAB-2
Maintenance Bond	MB-1 : MB-2
Surety Authorization Letter	SA-1
Missouri Project Exemption Certificate	MOPEC-1
Missouri Division of Labor Standards/Annual Wage Order No. 30	AWO-1 : AWO-4
Missouri Statement of Compliance	MO-SC-1
Missouri Affidavit of Compliance	AFC-1
Notice to Proceed	NTP-1
Contractor's Affidavit and Release for Partial Payment	APP-1
Receipt and Release Final	RR-1
Final Consent of Surety	CS-1
Certificate of Substantial Completion	CSP-1
General Conditions Table of Contents	GC-i : GC-iii
General Conditions	GC-1 : GC-44
Project Special Conditions	SC-1 : SC-3
Technical Specifications	
Portland Cement Concrete	PCC-1 : PCC-11
Appendix	
List of Improvements	L-1
Details	D-1 : D-7

CITY OF GRAIN VALLEY, MISSOURI
(“Owner”)
COMMUNITY DEVELOPMENT DEPARTMENT
2024 CONCRETE REPLACEMENT AND PAVING PROGRAM
ADVERTISEMENT FOR BIDS

Sealed Bids will be received by the City of Grain Valley at City Hall, 711 Main Street, Grain Valley, Missouri until **2:00 p.m. on March 14, 2024**. At said place and time, all Bids that have been duly received will be publicly opened and read aloud in the Lower Level Conference Room.

The Work is generally described as follows:

2024 CONCRETE REPLACEMENT AND PAVING PROGRAM

All Bids must be in accordance with the Bidding Documents, including, Drawings, Specifications, and Contract Documents on file at the Community Development Department, located in City Hall, 711 Main Street, Grain Valley, Missouri.

Copies of plans, specifications, bid documents, and other Contract Documents can be seen and downloaded on-line at www.cityofgrainvalley.org. Information regarding this project can be found under the “Bid Notices” link on the website. Prospective bidders desiring hard copies of the Contract Documents for use in preparing bids may obtain a set of such documents from the City of Grain Valley Community Development Department, 711 S. Main Street, Grain Valley, MO 64029. Any questions regarding the project, plans, specification, or bid documents should be directed to Richard Tuttle, City Engineer at (816) 847-6222 or dtuttle@cityofgrainvalley.org.

Bids will be received on a unit price basis.

Each Bid shall be accompanied by a certified check, made payable to the City of Grain Valley, Missouri in an amount not less than five percent (5%) of the total Bid or by a Bid Bond with a Surety licensed to do business in the State of Missouri in the amount of five percent (5%) of the total Bid. This Security may be retained by the Owner until the Contract for the Project has been fully executed.

The Contractor and all subcontractors will be required to comply with all applicable Federal and State labor regulations including Equal Employment Opportunity, Non-segregated Facilities, Minimum Wage Rates and Affirmative Action requirements. The City of Grain Valley hereby notifies all Bidders that it will affirmatively ensure that in any Contract entered into pursuant to this Advertisement, minority business enterprises will be afforded full opportunity to submit Bids without discrimination, regardless of race, color, or national origin in consideration for any award.

Wage rates paid for Work for this Project shall be at least equal to the prevailing wage rates as determined by the Division of Labor Standards of the State of Missouri.

The project contractor and each subcontractor shall require each on-site employee to complete the ten-hour safety program required under Section 292.675, RSMo, within 30 days of beginning any of the work on the project if he or she has not previously completed the program or does not have documentation of having done so.

All bids are subject to the Buy Local/American policy and any other applicable purchasing statutes of the State of Missouri.

No bidder may withdraw its Bid within 90 days after the actual date of the opening of Bids. The City of Grain Valley, Missouri reserves the right to award the Contract by sections, to reject any or all Bids, and to waive any informalities or irregularities therein.

Owner: City of Grain Valley, Missouri

Date: February 23, 2024

PRE-BID CONFERENCE

A pre-Bid conference will be held at City of Grain Valley, City Hall Lower Level Conference Room, 711 Main Street, Grain Valley, Missouri, 2:00 p.m. on March 7, 2024. Representatives of Owner will be present to discuss the Project. Bidders are encouraged to attend and participate in the conference. Owner will transmit to all prospective Bidders of record such Addenda as Owner considers necessary in response to questions arising at the conference. Oral statements may not be relied upon and will not be binding or legally effective.

City of Grain Valley, Missouri
711 Main ♦ Grain Valley, MO 64029
Phone: (816) 847-6200 ♦ Fax: (816) 847-6209

2024 Concrete Replacement and Paving Program

INSTRUCTIONS TO BIDDERS

ARTICLE 1 - DEFINED TERMS

1.01 Terms used in these Instructions to Bidders will have the meanings indicated in the General Conditions of the Contract for Construction and any Supplementary Conditions as contained in the Bidding Documents. Additional terms used in these Instructions to Bidders have the meanings indicated below which are applicable to both singular and plural thereof:

- A. *Bid* - The offer of a Bidder submitted on the prescribed form contained in the Bidding Documents setting forth the price(s) for the Work to be performed.
- B. *Bidder* - The entity who submits a Bid for the Work described in the Contract Documents.
- C. *Bidding Documents* - The Bidding Requirements and the Contract Documents (including *without* limitation all Drawings, Specifications and Addenda issued prior to receipt of Bids).
- D. *Bidding Requirements* - The Advertisement for Bids or Invitation to Bid, these Instructions to Bidders, the Bid Form and *required* attachments as set forth in the Bidding Documents and Bid Security.
- E. *Bid Security* - The deposit of an approved Bid Bond, Cashier's Check or Certified Check furnished by the Bidder and made payable to the Owner for the amount stipulated in the Advertisement for Bids or Invitation to Bid.
- F. *Owner* - City of Grain Valley, Missouri, 711 Main, Grain Valley, Missouri 64029.

ARTICLE 2 - COPIES OF BIDDING DOCUMENTS

2.01 Complete sets of the Bidding Documents may be obtained from Owner as set forth in the Advertisement for Bids. A copy of the Bidding Documents are on file with the Owner at the City of Grain Valley, Missouri, 711 Main, Grain Valley, Missouri 64029.

2.02 Complete sets of Bidding Documents must be used in preparing Bids; Owner assumes no responsibility for errors or misinterpretations resulting from the use of incomplete sets of Bidding Documents.

2.03 Owner in making copies of the Bidding Documents available on the above terms do so only for the purpose of obtaining Bids for the Work and do not confer a license or grant for any other use.

ARTICLE 3 - QUALIFICATIONS OF BIDDERS

3.01 The Bidder must be qualified by experience, adequate financing, and equipment to perform the Work required by the Contract within the Contract Times.

3.02 To document Bidder's qualifications to perform the Work, within five (5) days of Owner's request, Bidder shall submit written evidence such as financial data, previous experience, qualifications of personnel, present commitments, and other data regarding Bidder's qualifications.

ARTICLE 4 - EXAMINATION OF BIDDING DOCUMENTS AND SITE

4.01 It is the responsibility of each Bidder, before submitting a Bid, to (a) thoroughly examine the Bidding Documents, (b) visit the site to become familiar with local conditions that may affect cost, progress, performance, or furnishing of the Work, (c) consider federal, state, and local laws and regulations that may affect cost, progress, performance, or furnishing of the Work, (d) study and carefully correlate Bidder's observations with the Bidding Documents, and (e) notify the City of all conflicts, errors, or discrepancies discovered by Bidder in the Bidding Documents.

4.02 Bidder must carefully study all reports of explorations and tests of subsurface conditions at or contiguous to the site and all drawings of physical conditions in or relating to existing surface or subsurface structures at or contiguous to the site which have been made available to Bidder, but Bidder shall not be entitled to rely upon the accuracy or completeness of such reports or tests. Such reports and drawings are not Contract Documents and may not be complete for Bidder's purposes, including without limitation, any reports or test described on Exhibit A hereto. Owner does not assume responsibility for the accuracy or completeness of information and data shown or indicated in the Bidding Documents with respect to subsurface conditions, physical conditions or underground facilities at or contiguous to the site. Bidder must obtain and carefully study, and assume responsibility for all such additional or supplementary examinations, investigations, explorations, tests, studies, and data concerning conditions, including, but not limited to, surface, subsurface, and underground facilities, at or contiguous to the site or otherwise which may affect cost, progress, performance, or furnishing of the Work or which relate to any aspect of the means, methods, techniques, sequences, and procedures of construction to be employed by Bidder and safety precautions and programs incident thereto as Bidder deems necessary. Any discrepancies between the reports and drawings made available to the Bidder and the information revealed in the Bidder's own examinations, tests, studies, explorations or investigations of any type shall be immediately reported in writing by the Bidder to Professional.

4.03 Provisions concerning responsibilities for the adequacy of data furnished to prospective Bidders on subsurface conditions, underground facilities, and other physical conditions appear in the General Conditions.

4.04 Before submitting a Bid, each Bidder will be responsible to make or obtain such explorations, tests, and data concerning physical conditions, surface, subsurface, and underground facilities at or contiguous to the site or otherwise which may affect cost, progress, performance, or furnishing of the Work and which Bidder deems necessary to determine its Bid for performing and furnishing the Work in accordance with the time, price, and other terms and conditions of the Contract Documents. On reasonable notice, Owner will provide each Bidder access to the site to conduct such explorations and tests as each Bidder deems necessary for submission of a Bid. Bidder shall fill all holes, clean up, and restore the site to its former condition upon completion of such explorations. Each Bidder wishing to inspect the site and any existing facilities shall contact:

Richard J. Tuttle, P.E. City Engineer | 816.847.6222 | dtuttle@cityofgrainvalley.org

Michael Myers | 816.847.6272 | mmyers@cityofgrainvalley.org

4.05 The submission of a Bid will constitute an incontrovertible representation by Bidder that Bidder has complied with the provisions of Section 4 of the Instructions to Bidders, that without exception the Bid is premised upon performing and furnishing the Work required by the Contract Documents, that Bidder has given Professional written notice of all conflicts, errors, ambiguities, and discrepancies that Bidder has discovered in the Bidding Documents and the written resolutions thereof by Professional are acceptable to Bidder, and that the Bidding Documents are sufficient in scope and detail to indicate and convey understanding of all terms and conditions for performance and furnishing of the Work.

ARTICLE 5- SITE AND OTHER AREAS

5.01 The lands upon which the Work is to be performed and access thereto, and other lands designated for use by Contractor in performing the Work are identified in the Bidding Documents. All additional lands and access thereto required for temporary construction facilities, construction equipment, or storage of materials and equipment to be incorporated in the Work are to be obtained and paid for by Contractor.

ARTICLE 6 - INTERPRETATIONS AND ADDENDA

6.01 All questions about the meaning or intent of the Bidding Documents are to be directed to Professional. Questions concerning the Bidding Documents may be directed to:

Richard J. Tuttle, City Engineer I816.847.6222 |
dtuttle@cityofgrainvalley.org

6.02 Interpretations or clarifications considered necessary by Owner in response to such questions will be issued by Addenda. Questions received less than four (4) days prior to the date for the receipt of Bids may not be answered. Only answers issued by formal written Addenda will be binding. Oral and other interpretations or clarifications will be without legal effect. Addenda may also be issued to modify the Bidding Documents as deemed advisable by Professional. Such Addenda must also be in writing in order to be binding.

ARTICLE 7 - BID SECURITY

7.01 A Bid must be accompanied by Bid security made payable to Owner in an amount of five percent (5%) of Bidder's maximum Bid Price and in the form of a certified or bank check or a Bid Bond on the form attached issued by a surety meeting the requirements of the General Conditions.

7.02 The Bid Security of the Successful Bidder will be retained until such Bidder has executed the Contract Documents, furnished the required Contract Security and met the other conditions of the Notice of Award, whereupon the Bid Security will be returned. If the Successful Bidder fails to execute and deliver the Contract Documents and furnish the required contract security within fifteen (15) days after the Notice of Award, Owner may annul the Notice of Award and the Bid Security of that Bidder will be forfeited. The Bid Security of other Bidders whom Owner believes to have a reasonable chance of receiving the award may be retained by Owner until the earlier of seven (7) days after the Effective Date of the Agreement or ninety one (91) days after the Bid opening, whereupon Bid Security furnished by such Bidders will be returned.

7.03 Bid Security of other Bidders whom Owner believes do not have a reasonable chance of receiving the award will be returned within seven (7) days after the Bid opening.

ARTICLE 8 - CONTRACT TIMES

8.01 The Contract Times shall be the dates by which: (a) Contractor shall achieve Substantial Completion of the entire Work; and (b) Contractor shall achieve Final Completion of the entire Work. The Contract Times for the Project are set forth in Article 3 of the Agreement Between Owner and Contractor.

ARTICLE 9 - LIQUIDATED DAMAGES

9.01 Provisions for liquidated damages are set forth in Article 3 of the Agreement.

ARTICLE 10 - SUBSTITUTE AND "OR-EQUAL" ITEMS

10.01 The Contract, if awarded, will be on the basis of materials and equipment specified or described in the Bidding Documents without consideration of possible substitute or "or-equal" items. Whenever it is specified or described in the Bidding Documents that a substitute or "or-equal" item of material or equipment may be furnished or used by Contractor if acceptable to Owner, application for such acceptance will not be considered by Owner until after the Effective Date of the Agreement. The procedure for submission of any such application by Contractor and consideration by Owner is set forth in the General Conditions and may be supplemented in the General Requirements or the Supplementary Conditions.

ARTICLE 11 - SUBCONTRACTORS, SUPPLIERS AND OTHERS

11.01 If the Supplementary Conditions require the identity of certain Subcontractors, Suppliers, individuals, or entities to be submitted to Owner in advance of a specified date prior to the Effective Date of the Agreement, the apparent Successful Bidder, and any other Bidder so requested, shall within *five* (5) days after Bid opening, submit to Owner a list of all such Subcontractors, Suppliers, individuals, or entities proposed for those portions of the Work for which such identification is required. Such list shall be accompanied by an experience statement with pertinent information regarding similar projects and other evidence of qualification for each such Subcontractor, Supplier, individual or entity if requested by Owner. If Owner or Professional after due investigation has reasonable objection to any proposed Subcontractor or Supplier, Owner may, before the Notice of Award is given, require the apparent Successful Bidder to submit a substitute, in which case, apparent Successful Bidder shall submit an acceptable substitute, and Bidder's Bid price will be adjusted in accordance with Paragraph 6.09 of the General Conditions.

11.02 Contractor shall not be required to employ any Subcontractor, Supplier, individual, or entity against whom Contractor has reasonable objection.

ARTICLE 12-PREPARATION OF BID

12.01 The Bid Form is provided in the Bidding Documents. Bid Forms must be fully completed in ink or typewritten and include all required attachments.

12.02 Bids by corporations must be executed in the corporate name by the president or vice-president (or other corporate officer accompanied by evidence of authority to sign), and the corporate seal shall be affixed and attested by the secretary or an assistant secretary. The state of incorporation shall be shown below the corporate name. Bids by partnerships must be executed in the partnership name and signed by a partner (accompanied by evidence of authority to sign) and the official address of the partnership must be shown below the signature. Bids by joint ventures shall be signed by each participant in the joint venture or by an authorized agent of each participant. Bids by limited liability companies shall be executed in the name of the firm by a member and accompanied by evidence of authority to sign. The state of formation of the firm

and the official address of the firm must be shown below the signature. All names shall be typed or printed in ink below the signatures. The address and telephone number for communications regarding the Bid shall be shown.

12.03 A Bid by a person who affixes to his signature the word "president", "secretary", "agent", or other designation without disclosing his principal may be held to be the bid of the individual signing.

12.04 All blank spaces in the Bid Form shall be filled.

12.05 The Bid shall contain an acknowledgment of receipt of all Bidding Documents.

12.06 Each Bid shall be accompanied by an executed Affidavit in the form attached hereto.

ARTICLE 13 - BASIS OF BID

13.01 The Bidder shall complete the schedule of unit prices included in the Bid Form and shall accept all fixed unit prices listed therein. The total Bid will be calculated as the sum of the products of the estimated quantity of each item and the unit price bid. Discrepancies in the multiplication of units of Work and unit prices will be resolved in favor of the unit prices. Discrepancies between the indicated sum of any column of figures and the correct sum thereof will be resolved in favor of the correct sum. The unit prices set forth in the Bid Form shall be considered complete and include: (1) all materials, equipment, labor, delivery, installation, overhead and profit; and (2) any other costs or expenses in connection with, or incidental to, the performance of that portion of the Work to which such unit prices apply. Any estimated quantities of Work contained in any Bidding Document or Contract Document are not guaranteed and are solely for the purpose of comparison of Bids. Estimated quantities may change because of changes ordered by Owner or because of actual site conditions or other reasons. The unit prices for the Work shall remain unchanged even if the actual quantity of Work performed by Contractor differs materially and significantly from any estimated quantity of such items. Contractor agrees that it shall make no claim for an adjustment in any unit price for any variance between the actual quantity of Work performed by Contractor and any estimated quantity of such item.

ARTICLE 14 - SUBMISSION OF BIDS

14.01 Bids shall be submitted no later than the date and time prescribed in the Advertisement or Invitation for Bids, or the modified time and place indicated by Addendum. The unbound copy of the Bid Form is to be completed and accompanied by all other required documents, including the Bid Security.

14.02 Bids shall be enclosed in an opaque sealed envelope plainly marked as a "Bid" with the Project title and marked with the name and address of the Bidder. If the Bid is sent through the mail or other delivery system, the sealed envelope shall be enclosed in a separate envelope with the notation "BID ENCLOSED" on the face of it.

14.03 Bids received after the time and date for receipt of Bids will be returned unopened. Bidder shall assume full responsibility for timely delivery at the location designated for receipt of Bids. Oral, telephone, telegraph, or facsimile Bids are invalid and will not receive consideration.

ARTICLE 15- MODIFICATION AND WITHDRAWAL OF BIDS

15.01 Bids may be modified or withdrawn by an appropriate document duly executed in the manner that a Bid must be executed and delivered to the place where Bids are to be submitted at any time prior to the opening of Bids.

ARTICLE 16-OPENING OF BIDS

16.01 Bids will be opened and read aloud publicly. An abstract of the amounts of the base Bids will be made available to Bidders after the opening of Bids.

ARTICLE 17- BIDS TO REMAIN SUBJECT TO ACCEPTANCE

17.01 All Bids will remain subject to acceptance for 90 days after the day of the Bid opening, but Owner may, in its sole discretion, release any Bid and return the Bid security prior to that date. Any extension of the commencement date for Work as specified in the Contract Documents shall be governed by the applicable provisions of the Contract Documents and shall not be grounds for withdrawal of a Bid.

ARTICLE 18-APPROVAL BY BOAD OF ALDERMAN

18.01 The Contract will not be binding and effective on the City until approved by Resolution of the Board of Alderman of Grain Valley, Missouri.

ARTICLE 19-AWARD OF CONTRACT

19.01 Owner reserves the right to reject any and all Bids, including, without limitation, the right to reject any or all bids which in the Owner's discretion are nonconforming, nonresponsive, unbalanced, or conditional Bids and to reject the Bid of any Bidder if Owner believes that it would not be in the best interest of the Project to make an award to that Bidder, whether because the Bid is not responsive or the Bidder is unqualified or of doubtful financial ability or fails to meet any other pertinent standard or criteria established by Owner. Owner also reserves the right to waive all informalities not involving price, time, or changes in the Work.

19.02 In evaluating Bids, Owner will consider the qualifications of the Bidders, whether or not the Bids comply with the prescribed requirements, and such alternatives, unit prices, and other data, as may be requested in the Bid Form or prior to the Notice of Award.

19.03 Owner may conduct such investigations as Owner deems necessary to assist in the evaluation of any Bid and to establish the responsibility, qualifications, and financial ability of Bidders, proposed Subcontractors, Suppliers, and other persons and organizations to perform and furnish the Work in accordance with the Contract Documents to Owner's satisfaction within the prescribed time.

19.04 If the Contract is to be awarded, it will be awarded to the lowest, responsive and responsible Bidder whose evaluation by Owner indicates to Owner that Bidder is responsible and qualified to perform the Work.

19.05 More than one Bid for the same Work from an individual or entity under the same or different names will not be considered. Reasonable grounds for believing that any Bidder has an interest in more than one Bid for the Work may be cause for disqualification of that Bidder and the rejection of all Bids in which that Bidder has an interest.

ARTICLE 20- CONTRACT SECURITY AND INSURANCE

20.01 The General Conditions as may be modified by the Supplementary Conditions, set forth the requirements as to Performance and Payment Bonds and insurance. When the Successful Bidder delivers the executed Agreement to Owner, it must be accompanied by the required Performance and Payment Bonds.

ARTICLE 21- EXECUTION OF AGREEMENT AND BONDS

21.01 When Owner gives a Notice of Award to the Successful Bidder, it will be accompanied by unsigned counterparts of the Agreement with other written Contract Documents attached; the required number of copies will be determined by Owner. Within fifteen (15) days thereafter Contractor shall sign, leaving the dates blank, and deliver the required number of counterparts of the Agreement and attached documents to Owner with the required Bonds and power of attorney. After confirmation of the Contract by action of the City, if required, or within fifteen (15) days if not required, Owner shall execute all copies of the Agreement and other Contract Documents submitted by Contractor/Successful Bidder, insert the date of Contract on the Agreement, Bonds, and power of attorney, and return all copies to Contractor for distribution. Distribution of signed copies shall be as directed by Owner.

ARTICLE 22- TAXES AND PERMITS

22.01 Responsibility for payment of taxes and permits is set forth in the General Conditions. As set forth in the General Conditions, certain equipment and materials are exempt from State and Local Sales and Use taxes. Said taxes shall not be included in the Bid.

ARTICLE 23- LAWS AND REGULATIONS

23.01 Provisions concerning Laws and Regulations are set forth in the Contract Documents.

23.02 Bids shall be based on payment by Contractor and each Subcontractor of wage rates not less than the prevailing hourly wage for each craft or classification of workmen engaged on the Work as determined by the Industrial Commission of Missouri on behalf of the Department of Labor and Industrial Relations. Higher prevailing wage rates may apply if a federal governmental agency is providing funding for this Project. Requirements regarding payment of prevailing wage rates are set forth in the General Conditions.

23.03 Information on the Missouri Domestic Product Procurement (Buy American) Act is contained in the General Conditions.

23.04 A pre-Bid conference will be held at City of Grain Valley, City Hall Lower Level Conference Room, 711 Main Street, Grain Valley, Missouri, 2:00 p.m. on January 24, 2023. Representatives of Owner will be present to discuss the Project. Bidders are encouraged to attend and participate in the conference. Owner will transmit to all prospective Bidders of record such Addenda as Owner considers necessary in response to questions arising at the conference. Oral statements may not be relied upon and will not be binding or legally effective.

23.05 Successful bidder must obtain a City of Grain Valley Business License prior to the start of work.

EXHIBIT A
REPORTS AND DRAWINGS REFERRED TO IN PARAGRAPH 4.02

NONE

AFFIDAVIT of COMPLIANCE

(Section 285.530.2, Revised Statutes of Missouri)

State of Missouri

County of _____) ss:
_____)

Now this ___ day of ___, 2024 the undersigned being first duly sworn, deposes and says:

1. I am more than 18 years of age.
2. I make this affidavit from my personal knowledge of the facts stated herein or upon information and facts available to me as a duly authorized owner, partner, corporate, or LLC officer or Human Relations Director of _____ ("Contractor").
3. I am authorized to make this affidavit on behalf of Contractor.
4. I state and affirm that Contractor is enrolled and is currently participating in E-Verify, a federal work authorization program or another equivalent electronic verification of work authorization program operated by the United States Department of Homeland Security under the Immigration Reform and Control Act of 1986.
5. Further, Contractor does not knowingly employ any person who is an unauthorized alien.
6. Further, Contractor has performed an electronic verification check as described above on all workers hired since January 1, 2009 or obtained documents required for completion of a Federal 1-9 form before it began participating in E-Verify.
7. Attached to this affidavit is a true and accurate copy of Contractor's Memorandum of Understanding with the United States concerning the use of E-Verify.

I certify under penalty of perjury that the statements above are complete, true and accurate to the best of my knowledge and belief.

Authorized Agent, Partner, Owner or Officer

Printed Name

Title

If Contractor has a Human Relations Director or equivalent that person must sign as an affiant as well.

I certify under penalty of perjury that the statements above are complete, true and accurate to the best of my knowledge and belief.

Human Relations Director

Printed Name

Title

Subscribed and sworn to before me this__ day of _____,20__.

Notary Public

My commission expires:

This form is promulgated pursuant to 15CSR 60-15.020. Use of this form is not required but the Attorney General has deemed this affidavit sufficient in form to satisfy the requirements of section 285.540 RSMo., Supp. 2008.

I further depose and state that Bidder has not received any payment or gratuity from a Subcontractor or Supplier, as an inducement for the award of a subcontract or a purchase order.

The undersigned further warrants that he or she has the authority to execute this affidavit on behalf of the Bidder.

Signature

, before me, a Notary Public, personally appeared

to me known to be the person who executed the within Bidder's Affidavit, and acknowledged to me that he/she executed the same for the purposes therein stated.

Notary Public

My commission expires:

BID FORM

2024 TABLE OF CONTENTS

	Page
ARTICLE 1- Bid Recipient	1
ARTICLE 2 - Bidder's Acknowledgements	1
ARTICLE 3 - Bidder's Representations	1
ARTICLE 4- Bidder's Certification.....	2
ARTICLE 5 - Basis of Bid.....	3
ARTICLE 6-Time of Completion.....	4
ARTICLE 7 -Attachments to this Bid.....	4
ARTICLE 8 - Bid Submittal.....	5

ARTICLE 1- BID RECIPIENT

1.01 This Bid is submitted to:

City of Grain Valley, Missouri
C/O Richard Tuttle, City Engineer
711 Main
Grain Valley, Missouri 64029

1.02 The undersigned Bidder proposes and agrees, if this Bid is accepted, to enter into an Agreement with Owner in the form included in the Bidding Documents to perform all Work as specified or indicated in the Bidding Documents for the prices and within the times indicated in this Bid and in accordance with the other terms and conditions of the Bidding Documents.

ARTICLE 2 - BIDDER'S ACKNOWLEDGEMENTS

2.01 Bidder accepts all of the terms and conditions of the Instructions to Bidders, including without limitation those dealing with the disposition of Bid security. This Bid will remain subject to acceptance for 90 days after the Bid opening, or for such longer period of time that Bidder may agree to in writing upon request of Owner.

ARTICLE 3 - BIDDER'S REPRESENTATIONS

3.01 In submitting this Bid, Bidder represents that:

A. Bidder has examined and carefully studied the Bidding Documents, and any data and reference items identified in the Bidding Documents, and hereby acknowledges receipt of the following Addenda:

Addendum No.	Addendum, Date
_____	_____
_____	_____
_____	_____
_____	_____

- B. Bidder has visited the Site, conducted a thorough, alert visual examination of the Site and adjacent areas, and become familiar with and satisfied itself as to the general, local, and Site conditions that may affect cost, progress, and performance of the Work.
- C. Bidder is familiar with and has satisfied itself as to all Laws and Regulations that may affect cost, progress, and performance of the Work.
- D. Bidder has carefully studied all: (1) reports of explorations and tests of subsurface conditions at or adjacent to the Site and all drawings of physical conditions relating to existing surface or subsurface structures at the Site that have been identified in the Supplementary Conditions, especially with respect to Technical Data in such reports and drawings, and (2) reports and drawings relating to Hazardous Environmental Conditions, if any, at or adjacent to the Site that have been identified in the Supplementary Conditions, especially with respect to Technical Data in such reports and drawings.

Bidder has considered the information known to Bidder itself; information commonly known to contractors doing business in the locality of the Site; information and observations obtained from visits to the Site; the Bidding Documents; and any Site-related reports and drawings identified in the Bidding Documents, with respect to the effect of such information, observations, and documents on (1) the cost, progress, and performance of the Work; (2) the means, methods, techniques, sequences, and procedures of construction to be employed by Bidder; and (3) Bidder's safety precautions and programs.

- E. Bidder agrees, based on the information and observations referred to in the preceding paragraph, that no further examinations, investigations, explorations, tests, studies, or data are necessary for the determination of this Bid for performance of the Work at the price bid and within the times required, and in accordance with the other terms and conditions of the Bidding Documents.
- F. Bidder is aware of the general nature of work to be performed by Owner and others at the Site that relates to the Work as indicated in the Bidding Documents.
- G. Bidder has given Engineer written notice of all conflicts, errors, ambiguities, or discrepancies that Bidder has discovered in the Bidding Documents and confirms that the written resolution thereof by Engineer is acceptable to Bidder.
- H. The Bidding Documents are generally sufficient to indicate and convey understanding of all terms and conditions for the performance and furnishing of the Work.
- I. The submission of this Bid constitutes an incontrovertible representation by Bidder that Bidder has complied with every requirement of this Article, and that without exception the Bid and all prices in the Bid are premised upon performing and furnishing the Work required by the Bidding Documents.

ARTICLE 4 - BIDDER'S CERTIFICATION

4.01 Bidder certifies that:

- A. This Bid is genuine and not made in the interest of or on behalf of any undisclosed individual or entity and is not submitted in conformity with any collusive agreement or rules of any group, association, organization, or corporation;
- B. Bidder has not directly or indirectly induced or solicited any other Bidder to submit a false or sham Bid;
- C. Bidder has not solicited or induced any individual or entity to refrain from bidding; and
- D. Bidder has not engaged in corrupt, fraudulent, collusive, or coercive practices in competing for the Contract. For the purposes of this Paragraph 4.01.D:
 - 1. "corrupt practice" means the offering, giving, receiving, or soliciting of anything of value likely to influence the action of a public official in the bidding process;
 - 2. "fraudulent practice" means an intentional misrepresentation of facts made (a) to influence the bidding process to the detriment of Owner, (b) to establish bid prices at artificial non-competitive levels, or (c) to deprive Owner of the benefits of free and open competition;

3. "collusive practice" means a scheme or arrangement between two or more Bidders, with or without the knowledge of Owner, a purpose of which is to establish bid prices at artificial, non-competitive levels; and
4. "coercive practice" means harming or threatening to harm, directly or indirectly, persons or their property to influence their participation in the bidding process or affect the e execution of the Contract.

ARTICLE 5 - BASIS OF BID

5.01 Bidder will complete the Work in accordance with the Contract Documents for the following price(s):

Project 2- Concrete Replacement and Paving

Item No.	Description	Units	Quantity	Unit Price	Extension
1	CG-2 Curb Replacement	LF	2,604		
2	New 4-inch Thick Sidewalk	SF	11,470		
3	Replacement 4-Inch Thick Sidewalk	SF	1,000		
4	Sidewalk ADA Ramp	SF	2,260		
5	Sidewalk Detectible Warning	SF	705		
6	6-inch Thick Reinforced Slab	SF	625		
7	Replace 6-inch Thick Reinforced Concrete Driveway Approach	SF	852		
8	Traffic Control	LS	1		
9	Force Account (Set)	FA	1	\$10,000.00	\$10,000.00
Total Amount of Base Bid					

Total Amount of Bid for Project (Typed or Written)

The City reserves the right to adjust quantities for budget purposes

Bidder acknowledges that (1) each Bid Unit Price includes an amount considered by Bidder to be adequate to cover Contractor's overhead and profit for each separately identified item, and (2) estimated quantities are not guaranteed, and are solely for the purpose of comparison of Bids, and final payment for all unit price Bid items will be based on actual quantities, determined as provided in the Contract Documents.

ARTICLE 6 -TIME OF COMPLETION

- 6.01 Bidder agrees that the Work will be substantially complete within 90 days of Notice to Proceed and will be completed and ready for final payment in accordance with Paragraph 14.10 of the General Conditions within 15 days of final punch list.
- 6.02 Bidder accepts the provisions of the Agreement as to liquidated damages.

ARTICLE 7 -ATTACHMENTS TO THIS BID

- 7.01 The following documents are submitted with and made a condition of this Bid:
- A. Required Bid security;
 - B. Bidders Affidavit;
 - C. E-Verify Affidavit;
 - D. List of Proposed Subcontractors;
 - E. List of Proposed Suppliers;
 - F. List of Equipment;
 - G. List of Contracts on Hand;
 - H. Evidence of authority to do business in the state of Missouri; or a written covenant to obtain such license within the time for acceptance of Bids;
 - I. Contractor's License No.: [or] Evidence of Bidder's ability to obtain a State Contractor's License and a covenant by Bidder to obtain said license within the time for acceptance of Bids;
 - J. All manufactured goods or commodities used or supplied under this contract must meet the requirements of the Domestic Products Procurement law RSMo 34.350 - RSMo 34.359. Compliance certification must be submitted with the bid.
- 7.02 The terms used in this Bid with initial capital letters have the meanings stated in the Instructions to Bidders, the General Conditions, and the Supplementary Conditions.

ARTICLE 8 - BID SUBMITTAL

BIDDER: *[Indicate correct name of bidding entity]*

By:
[Signature] _____

[Printed name]
{If Bidder is a corporation, a limited liability company, a partnership, or a joint venture, attach evidence of authority to sign.}

Attest:
[Signature] _____

[Printed name] _____

Title: _____

Submittal Date: _____

Address for giving notices:

Telephone Number: _____

Fax Number: _____

Contact Name and e-mail address: _____

Bidder's License No.: _____
(where applicable)

BID BOND

Any singular reference to Bidder, Surety, Owner or other party shall be considered plural where applicable.

BIDDER (Name and Address):

SURETY (Name and Address of Principal Place of Business):

OWNER (Name and Address):

City of Grain Valley, Missouri
711 Main Street
Grain Valley, MO 64029

PROJECT

Date:

Amount:

Description (Name and Location):

2024 Pavement Maintenance Program
Asphaltic Concrete Overlay

BOND

Date:

Amount:

Surety and Bidder, intending to be legally bound hereby, subject to the terms printed on the reverse side hereof, do each cause this Payment Bond to be duly executed on its behalf by its authorized officer, agent or representative.

BIDDER AS PRINCIPAL

Company: _____ (Corp. Seal)

Signature: _____
Name and Title: _____

SURETY

Company: _____ (Corp. Seal)

Signature: _____
Name and Title: _____
(Attach certified Power of Attorney)

NOW THEREFORE, Bidder and Surety jointly and severally agree to bind themselves, their heirs, executors, administrators, successors and assigns to pay to Owner upon default of Bidder the penal sum set forth on the face of the Bond and subject to the following terms and conditions:

1. Default of Bidder shall occur upon the failure of Bidder to deliver within the time required by the Bidding Documents the executed Agreement required by the Bidding Documents and the performance and payment bonds required by the Bidding Documents and Contract Documents.
2. This obligation shall be null and void if:
 - a. Owner accepts Bidder's bid and Bidder delivers within the time required by the Bidding Documents (or any extension thereof agreed to in writing by Owner) the executed Agreement required by the Bidding Documents and the performance and payment bonds required by the Bidding Documents and Contract Documents, or
 - b. All bids are rejected by Owner, or
 - c. Owner fails to issue a notice of award to Bidder within the time specified in the Bidding Documents (or any extension thereof agreed to in writing by Bidder.
3. Payment under this Bond will be due and payable upon default of Bidder and within ten (10) calendar days after receipt by Bidder and Surety of written notice of default from Owner.
4. Notice required hereunder shall be in writing and sent via U.S. Mail or hand delivered to both Bidder and Surety at their respective addresses shown on the face of this Bond and shall be deemed to be effective upon receipt by the party concerned.
5. Surety waives notice of and any and all defenses based on or arising out of any time extension to issue notice of award agreed to in writing by Owner and Bidder.
6. Surety shall cause to be attached to this Bond a current and effective Power of Attorney evidencing the authority of the officer, agent or representative who executed this Bond on behalf of Surety to execute, seal and deliver such Bond and bind the Surety thereby.
7. This Bond is intended to conform to all applicable laws. Any applicable requirement of any applicable law that has been omitted from this Bond shall be deemed to be included herein as if set forth at length. If any provision of the Bond conflicts with any applicable provision of any applicable law, then the provisions of said laws shall govern and the remainder of this Bond that is not in conflict therewith shall continue in full force and effect.

Address of Owner:

City of Grain Valley, Missouri
711 Main Street
Grain Valley, MO 64029

Address of Bidder:

[Insert Name and Address]

Address of Surety:

[Insert Name and Address]

BID GUARANTY

Attached hereto is a _____ Certified Check from _____ (the " Bidder") in the amount of _____ Dollars (\$ _____), which represents no less than five percent (5%) of the total Bid and payable to the City of Grain Valley, Missouri.

The Undersigned Bidder agrees that the accompanying Bid Security shall be forfeited to and become the property of the Owner should Bidder fail or refuse within the time required by the Bidding Documents to fully execute the Agreement as required by the Bidding Documents and timely delivery of a fully executed Performance Bond and Payment Bond required by the Bidding Documents and Contract Documents.

Dated this _____ day of _____, 20____

Name of Bidder (typed)

By: _____
(Authorized Signature)

Printed Name: _____

Title: _____

Address: _____

ATTEST:

Secretary (If Corporation)

Affix Corporate Seal

NOTICE OF AWARD

_____20_____

TO:

AT:

“Contractor”

FROM:

CITY OF GRAIN VALLEY, MISSOURI

711 Main Street
Grain Valley, MO 64029

“Owner”

**RE: 2024 Pavement Maintenance Program
Concrete Replacement and Pavement**

“Project”

You are notified that your Bid dated _____ for the referenced Contract has been evaluated. Your organization has been determined to be the lowest responsible and best Bidder, and has been awarded the Contract for the Work.

The Contract Price of your Contract is _____ Dollars (\$_____).

Five (5) copies of the Agreement Between Owner and Contractor accompany this Notice of Award.

Your organization shall comply with the following conditions precedent within the number of days after receipt of the Notice of Award specified in the Instruction to Bidders or otherwise stipulated, that is by _____, 20__ you shall:

Sign and return to the **Professional** the executed Notice of Award and all of the following required documents:

1. Five (5) fully executed counterparts of the Agreement Between Owner and Contractor
2. Fully executed Performance and Maintenance Bond and Payment Bond as specified in the General Conditions which may be modified by Supplementary Conditions.
3. Certificate of Insurance as specified the General Conditions which may be modified by Supplementary Conditions.

Failure to comply with these conditions within the time specified may entitle the Owner to consider your Bid abandoned, annul this Notice of Award and declare your Bid Security forfeited.

Issued On Behalf Of The Owner:

Contractor

By: _____

By: _____

Printed Name: Richard J. Tuttle

Printed Name: _____

Title: City Engineer

Title: _____

Received on _____, 20__

Return to the Professional: _____

2024 Concrete Replacement And Paving Program

AGREEMENT BETWEEN OWNER AND CONTRACTOR **(UNIT PRICE)**

THIS AGREEMENT BETWEEN OWNER AND CONTRACTOR (this "Agreement") is made and Entered into and is effective on this _____ day of _____, 2024, by and between the City of Grain Valley, Missouri, a municipality, ("Owner"), and _____ a _____, having its principal place of business located at _____ ("Contractor")

WHEREAS, Owner has caused to be prepared specifications, plans and other Contract Documents for the Work herein described, and has approved and adopted the Contract Documents defined herein and has invited proposals for furnishing materials, labor, and equipment for, and in connection with, the construction of improvements in accordance with the terms of the Contract Documents; and

WHEREAS, the Contractor, in response to the invitation, has submitted to Owner in the manner and at the time specified, a proposal in accordance with the terms of the Contract Documents; and

WHEREAS, Owner has opened, and examined the bids submitted and as a result of such examination, has determined and declared the Contractor to be the lowest and best bidder for constructing said improvements, and has duly awarded to this Contract to Contractor.

Owner and Contractor, in consideration of the mutual covenants herein set forth, agree as follows:

ARTICLE 1 **WORK**

Contractor, at his own cost and expense, will provide all labor, tools, equipment and materials required to complete all Work specified or indicated in the Contract Documents or reasonably inferable by the Contractor therefrom as necessary to produce the results intended by the Contract Documents.

ARTICLE 2 **PROFESSIONAL**

The Project has been designed by the City of Grain Valley, who is referred to in the Contract Documents as the Professional. Professional, and its duly authorized agents, are to act as Owner's representative, assume all duties and responsibilities, and have the rights and authorities assigned to Professional in the Contract Documents in accordance with the Contract Documents.

ARTICLE 3 **CONTRACT TIME AND COMPLETION**

3.1 The date of commencement is the date from which the Contract Time(s) of Paragraph 3.3 is measured and shall be fixed in a written notice to proceed issued by Owner.

3.2 The Contractor shall achieve Substantial and Final Completion of the entire Work, and if set forth below, the various designated stages of the Work, not later than the dates shown in Section 3.3.

3.3 Bidder agrees that the Work will be substantially complete within ninety (90) calendar days of Notice to Proceed and will be fully completed and ready for final payment in accordance with Paragraph 14.10 of the General Conditions within fifteen (15) calendar days following receipt of notice of substantial completion.

3.4 Time is of the essence to the Contract Documents and all obligations thereunder. The Contractor acknowledges and recognizes that (1) Owner is entitled to full and beneficial occupancy and use of the completed Work following expiration of the Contract Times and (2) Owner will sustain damages if the Contract Time(s) are not met by Contractor. The Contractor further acknowledges and agrees that if the Contractor fails to achieve Substantial Completion of the entire Work or any phase of the Work within the Contract Time(s), Owner will sustain extensive damages and serious loss as a result of such failure. The exact amount of such damages will be extremely difficult to ascertain. Therefore, Owner and the Contractor agree as follows in this Paragraph 3.4:

- .1 If the Contractor fails to achieve Substantial Completion of the Work or designated portions within the Contract Time(s) as set forth in Paragraph 3.3, Owner shall be entitled to retain or recover from the Contractor, as liquidated damages and not as a penalty, the following per diem amounts for each day that expires after the time specified in Paragraph 3.3 for Substantial Completion of the Work or designated phases of the Work and continuing until the actual Date(s) of Substantial Completion:

\$900 per Calendar Day

- .2 After Substantial Completion, if Contractor shall neglect, refuse or fail to complete remaining Work or designated portions within the Contract Time(s), as set forth in Paragraph 3.3, Owner shall be entitled to retain or recover from Contractor as liquidated damages and not as a penalty, the following per diem amounts for each day that expires after the time specified in Paragraph 3.3 for final completion of the Work or phases of the Work and until the actual date(s) of final completion:

\$900 per Calendar Day

- .3 All such liquidated damages referred to in this Paragraph 3.4 are hereby agreed to be a reasonable pre-estimate of damages Owner will incur as a result of delayed completion of the Work or phases of the Work. Owner may deduct liquidated damages described in Paragraph 3.4 from any unpaid amounts then or thereafter due the Contractor under this Agreement. Any liquidated damages not so deducted from any unpaid amounts due the Contractor shall be payable to Owner at the demand of Owner, together with interest from the date of the demand at a rate of one and one-half percent (1.5%) per month.

ARTICLE 4 **CONTRACT SUM**

4.1 Owner shall pay Contractor for completion of the Work in accordance with the Contract Documents and Contractor's bid an amount equal to the sum of the established unit price of each separately identified item of Work as set forth in the bid, times the actual quantities of that item completed by Contractor ("Contract Price"):

SEE ATTACHED BID

4.2 The unit prices set forth in the bid are considered complete and include: (1) all materials, equipment, labor, delivery, installation, overhead and profit; and (2) any other costs or expenses in connection with, or incidental to, the performance of that portion of the Work to which such unit prices apply.

4.3 Owner will determine the actual quantities and classifications of Unit Price Work performed by Contractor. Owner will review with Contractor's representative preliminary determinations on such matters before rendering a written decision thereon (by recommendation of an Application for Payment or otherwise). Owner's written decisions thereon will be final and binding upon Contractor, unless, within ten (10) days after the date of any such decision, Contractor delivers to Owner a written objection to such determination.

4.4 Any estimated quantities of Work contained in any Contract Document are not guaranteed and are solely for the purpose of comparison of Bids. Contractor acknowledges and agrees that the estimated quantities may change because of changes ordered by Owner or because of actual site conditions or other reasons. Contractor agrees that the unit prices for the Work shall remain unchanged even if the

actual quantity of Work performed by Contractor differs materially and significantly from any estimated quantity of such items. Contractor agrees that it shall make no claim for an adjustment in any unit price for any variance between the actual quantity of Work performed by Contractor and any estimated quantity of such item.

ARTICLE 5 PAYMENTS

5.1 Contractor shall submit Applications for Payment in accordance with the General Conditions of the Contract for Construction and in the form provided by Owner. Owner shall make progress payments to Contractor in accordance with the Contract Documents. The period covered by each Application for Payment shall be one (1) calendar month ending on the last day of the previous month.

5.2 The Application for Payment submitted by Contractor shall include the quantities of each item of Work completed by Contractor. Subject to the provisions of the Contract Documents, the amount of each progress payment shall be computed as follows:

- .1 The value of all completed Work by Contractor as determined by the sum of the unit price of each separately identified item of Work set forth in Paragraph 4.1 times the actual quantities of that item completed as determined by Owner as set forth in Paragraph 4.3;
- .2 Less retainage of five percent (5%) of the amount of Subparagraph .1;
- .3 Less the aggregate of previous payments made by Owner; and
- .4 Less amounts, if any, for which the Owner has withheld or nullified an approval of payment as set forth in the Contract Documents.

5.3 Owner shall make progress payments and final payment in accordance with the General Conditions of the Contract for Construction.

ARTICLE 6 CONTRACTOR'S REPRESENTATIONS

In order to induce Owner to enter into this Agreement, Contractor makes the following representations:

6.1 Contractor has examined and carefully studied the Contract Documents (including the Addenda listed in Article 7) and the other related data identified in the Bidding Documents including "technical data."

6.2 Contractor has visited the site and become familiar with and satisfied itself as to the general, local, and site conditions that may affect cost, progress, performance, or furnishing of the Work.

6.3 Contractor is familiar with and has satisfied itself as to all federal, state and local Laws and Regulations that may affect cost, progress, performance and furnishing of the Work.

6.4 Contractor has been provided any and all reports of explorations and tests of subsurface conditions at or contiguous to the site and all drawings of physical conditions in or relating to existing surface or subsurface structures at or contiguous to the site. Contractor acknowledges that such reports and drawings are not Contract Documents. A list of such reports and drawings are attached hereto as Exhibit A. Contractor acknowledges that Owner and Professional do not assume responsibility for the accuracy or completeness of such information. Contractor also acknowledges that Owner and Professional do not assume responsibility for the accuracy or completeness of data shown or indicated in the Contract Documents with respect to underground facilities or utilities at or contiguous to the site, and Contractor shall not be entitled to rely on the accuracy or completeness of such data. Contractor has obtained and carefully studied (or assumes responsibility for having done so) all such additional supplementary examinations, investigations, explorations, tests, studies, and data concerning conditions (surface, subsurface, and underground facilities and utilities) at or contiguous to the site or otherwise which may affect cost, progress, performance, or furnishing of the Work or which relate to any aspect of the means, methods, techniques, sequences, and procedures of construction to be employed by Contractor and safety precautions and programs incident thereto. Contractor does not consider that any additional examinations, investigations, explorations, tests, studies, or data are necessary for the performance and furnishing of the Work at the

Contract Sum, within the Contract Times, and in accordance with the other terms and conditions of the Contract Documents.

6.5 Contractor is aware of the general nature of work to be performed by Owner and others at the site that relates to the Work as indicated in the Contract Documents.

6.6 Contractor has correlated the information known to Contractor, information and observations obtained from visits to the site, reports and drawings identified in the Contract Documents, and all additional examinations, investigations, explorations, tests, studies, and data with the Contract Documents.

6.7 Contractor has given Owner written notice of all conflicts, errors, ambiguities, or discrepancies that Contractor has discovered in the Contract Documents and the written resolution thereof by Owner is acceptable to Contractor, and the Contract Documents are generally sufficient to indicate and convey understanding of all terms and conditions for performance and furnishing of the Work.

6.8 Contractor has the full power and authority to make, execute, deliver and perform the Work hereunder and has authorized the undersigned to bind it to this Contract and the Contract Documents.

6.9 The representations of Contractor shall be continuing and shall survive the execution and termination of this Contract.

ARTICLE 7
CONTRACT DOCUMENTS

The Contract Documents, except for Modifications executed after the date of this Contract, which comprise the entire agreement between Owner and Contractor concerning the Work, consist of the following:

- 7.1 This Agreement.
- 7.2 Exhibits to this Agreement, if any.
- 7.3 Notice to Proceed.
- 7.4 General Conditions of the Contract for Construction.
- 7.5 Supplementary Conditions of the Contract.
- 7.6 Performance Bond.
- 7.7 Payment Bond.
- 7.8 Maintenance Bond
- 7.9 Specifications of the Contract
- 7.10 The Drawings, as follows: standard details.
- 7.11 Addenda, if any, as follows:

<u>Number</u>	<u>Date</u>	<u>Pages</u>

7.12 Other documents, if any, as follows:

There are no Contract Documents other than those listed above in this Article 7 or the General Conditions of the Contract for Construction.

ARTICLE 8
MISCELLANEOUS

8.1 Terms used in this Contract which are defined in Article 1 of the General Conditions of the Contract for Construction will have the meanings indicated in the General Conditions of the Contract for

Construction.

8.2 Owner and Contractor each binds itself, its partners, successors, assigns, and legal representatives to the other party hereto, its partners, successors, assigns, and legal representatives in respect to all covenants, agreements, and obligations contained in the Contract Documents.

8.3 The business address of Contractor given herein is the place to which all notices, letters, and other communication to Contractor will be mailed or delivered. The address of Owner appearing herein is hereby designated as the place to which all notices, letters, and other communication to Owner shall be mailed or delivered. Either party may change his address at any time by an instrument in writing delivered to Professional and to the other party.

IN WITNESS WHEREOF, Owner and Contractor *have* signed this Contract by and through their duly authorized representatives. All portions of the Contract Documents *have* been signed or identified by Owner and Contractor or by Professional on their behalf.

THE CONTRACT DOCUMENTS CONTAIN AN ARBITRATION PROVISION WHICH MAY BE ENFORCED BY THE PARTIES

ATTEST:

**CITY OF GRAIN VALLEY, MISSOURI
"Owner"**

City Clerk

By: _____

Printed Name: Kenneth Murphy

Title: City Administrator

"Contractor"

By: _____

Printed Name: _____

Title: _____

PERFORMANCE BOND

Any singular reference to Contractor, Surety, Owner or other party shall be considered plural where applicable.

CONTRACTOR (Name and Address):

SURETY (Name and Address of Principal Place of Business):

OWNER:

City of Grain Valley, Missouri
711 Main Street
Grain Valley, MO 64029

CONTRACT

Date:
Price:
Description (Name and Location):

BOND

Date:
Amount:

Surety and Contractor, intending to be legally bound hereby, subject to the terms printed on the reverse side hereof, do each cause this Performance Bond to be duly executed on its behalf by its authorized officer, agent or representative.

CONTRACTOR AS PRINCIPAL

Company: _____ (Corp. Seal)

Signature: _____
Name and Title:

SURETY

Company: _____ (Corp. Seal)

Signature: _____
Name and Title:
(Attach certified Power of Attorney)

1. Contractor and the Surety, jointly and severally, bind themselves, their heirs, executors, administrators, successors and assigns to Owner and any successor, grantee or assignee of Owner for the full performance of all of Contractor's obligations under the Contract. The Contract is incorporated herein by this reference.
2. If the Contractor fully performs all of its duties and obligations under the Contract, the Surety and the Contractor shall have no obligation under this Bond.
3. The Surety's obligations under this Bond shall arise after:
 - a. The Contractor fails to fully perform of all its duties and obligations under the Contract;
 - b. The Owner has given Surety notice of Contractor's failure to fully perform of all its duties and obligations under the Contract; and
 - c. The Owner has agreed to pay the Balance of the Contract Price, if any, to the Surety in accordance with the terms of the Contract.
4. When Owner has satisfied the conditions of Paragraph 3, the Surety shall promptly and at Surety's expense take one of the following actions:
 - a. Arrange for Contractor, with the written consent of the Owner, to perform, complete or cure the default or breach of the Contract; or
 - b. Undertake to perform and complete the Contract itself through qualified contractors approved by Owner;
 - c. Waive its right to perform, complete or cure the default of breach of the Contract and pay to the Owner the total amount of this Bond.
5. If the Surety does not proceed as provided by Paragraph 4 within fifteen (15) days of the Owner's compliance with Paragraph 3 and complete its obligations with diligence and promptness, Surety shall be deemed to be in default under this Bond.
6. If Surety elects to act under Paragraph 4(a) or 4(b) above, then the responsibilities of Surety to Owner shall not be greater than those of the Contractor under the Contract, and the responsibilities of Owner to Surety shall not be greater than those of the Owner under the Contract. Surety recognizes and acknowledges that subject to the amount of the Bond, Surety's obligations under this Bond, include but are not limited to:
 - a. The responsibilities of Contractor for correction of defective work and completion of the Contract;
 - b. Attorneys' fees and design professional fees and delay costs resulting from Contractor's breach of or default under the Contract, or resulting from the acts or omissions of the Surety;
 - c. Liquidated damages, or if no liquidated damages are specified in the Contract, actual damages caused by the delayed performance or non-performance of the Contractor under the Contract or the Surety under this Bond.
7. The Surety shall not be liable to the Owner or others for obligations of the Contractor that are unrelated to the Contract, and the Balance of the Contract Price shall not be reduced or set off on account of any such unrelated obligations. No right of action shall accrue on this Bond to any person or entity other than the Owner.
8. The Surety hereby waives notice of any change, including changes of times, to the Contract or to related subcontracts, purchase orders and other obligations.
9. It is agreed by Contractor and Surety that notwithstanding any contrary provisions contained in this Bond or the Contract, that there shall be no limits on the Owner's right to sue under this Bond for defects, defaults, or breaches not discovered or known by Owner at the time such Work was paid for and accepted by Owner except those limits provided by the statute of limitations applicable to suits on contracts.
10. Surety further agrees that in event of any default by the Owner in the performance of the Owner's obligations to the Contractor under the Contract, the Contractor or Surety shall cause written notice of such default specifying said default in detail to be given to the Owner, and the Owner shall have thirty (30) days from time after receipt of such notice within which to cure such default, or such additional reasonable period of time as may be required if the nature of such default is such that it cannot be cured within thirty (30) days. Such Notice of Default shall be sent by certified or registered U.S. Mail, return receipt requested, first class postage pre-paid, to the Owner.
11. Surety further agrees this Bond shall remain in effect following the date of Final Payment during the Guarantee Period or the time required to resolve any items of incomplete Work and the payment of any disputed amounts for the period provided in the statute of limitations applicable to suits on contracts. This Bond shall be in an amount equal to the Contract Price and any adjustments thereto.
12. Surety agrees that it is obligated under the bonds to any successor, grantee or assignee of Owner.
13. Definitions
 - a. Balance of the Contract Price: The total amount payable by the Owner to the Contractor under the Contract after all proper adjustments have been made, including allowance to the Contractor of any amounts received or to be received by the Owner in settlement of insurance or other claims for damages to which the Contractor is entitled, reduced by all valid and proper payments made to or on behalf of the Contractor under the Contract.
 - b. Contract: The agreement between the Owner and the Contractor identified on the signature page, including all Contract Documents and changes thereto and including, but not limited to, all duties to correct or repair non-conforming Work.

Address of Owner:
 City of Grain Valley, Missouri
 711 Main Street
 Grain Valley, MO 64029

Address of Contractor/Principal:
 [Insert Name and Address]

Address of Surety:
 [Insert Name and Address]

PAYMENT BOND

Any singular reference to Contractor, Surety, Owner or other party shall be considered plural where applicable.

CONTRACTOR (Name and Address):

SURETY (Name and Address of Principal Place of Business):

OWNER (Name and Address):

City of Grain Valley, Missouri
711 Main
Grain Valley, MO 64029

CONTRACT

Date:

Amount:

Description (Name and Location):

BOND

Date:

Amount:

Surety and Contractor, intending to be legally bound hereby, subject to the terms printed on the reverse side hereof, do each cause this Payment Bond to be duly executed on its behalf by its authorized officer, agent or representative.

CONTRACTOR AS PRINCIPAL

Company: _____ (Corp. Seal)

Signature: _____

Name and Title:

SURETY

Company: _____ (Corp. Seal)

Signature: _____

Name and Title:

(Attach certified Power of Attorney)

1. The Contractor and the Surety, jointly and severally, bind themselves, their heirs, executors, administrators, successors and assigns to the Owner and any successor, grantee or assignee of Owner to pay for labor, materials and equipment furnished by Claimants for use in the performance of the Contract, which is incorporated herein by reference.

2. With respect to the Owner this obligation shall be null and void if the Contractor promptly makes payment, directly or indirectly, for all sums due Claimants.

3. With respect to Claimants, this obligation shall be null and void if the Contractor promptly makes payment for all sums due Claimants.

4. The Surety's total obligation shall not exceed the amount of this Bond.

5. Amounts due and payable by the Owner to the Contractor under the Contract shall be used for the performance of the Contract and to satisfy claims, if any, under the Performance Bond provided in connection with the Contract. By the Contractor furnishing this Bond, Contractor agrees that all remaining funds due and payable by the Owner to the Contractor in the performance of the Contract are dedicated to satisfy obligations of the Contractor and the Surety under this Bond subject to the Owner's priority to use the funds for the completion of the Work.

6. The Surety shall not be liable to the Owner, Claimants or others for obligations of the Contractor that are unrelated to the Contract. The Owner shall not be liable for payment of any costs or expenses of any Claimants under this Bond, and shall have under this Bond no obligation to make payments to, give notices on behalf of, or otherwise have obligations to Claimants under this Bond.

7. The Surety hereby waives notice of and consents to any changes, including changes of time, to the Contract or to related subcontracts, purchase orders and other obligations.

8. No suit or action shall be commenced by a Claimant under this Bond other than in a court of competent jurisdiction in the location of the Project or after the expiration of one year from the date which the last labor or service was performed by anyone or the last materials or equipment were furnished by anyone under the Contract. If the provisions of this Paragraph are void or prohibited by law, the minimum period of limitation available to sureties as a defense in the jurisdiction of the suit shall be applicable.

9. Notice to the Surety or the Contractor shall be mailed or delivered to the address shown on the signature page. Actual receipt of notice by Surety or the Contractor, however accomplished, shall be sufficient compliance as of the date received at the address shown on the signature page.

10. Any provision in the Bond conflicting with any applicable law shall be deemed deleted herefrom and provisions conforming to such applicable law shall be deemed incorporated herein.

11. Upon request by any person or entity appearing to be a potential beneficiary of this Bond, the Contractor or Surety shall promptly furnish a copy of this Bond or shall permit a copy to be made.

12. The Contract is hereby made a part of this bond.

13. Surety agrees that it is obligated under this Bond to any successor, grantee or assignee of the Owner.

14. DEFINITIONS

a. Claimants: Individuals or entities that furnish labor, materials or equipment for use in the performance of the Contract. The intent of this Bond shall be to include without limitation in the terms "labor, materials or equipment" that part of water, gas, power, light, heat, oil, gasoline, telephone service or rental equipment used in the Contract, design services required for performance of the Work of the Contractor and the Contractor's subcontractors.

b. Contract: The agreement between the Owner and the Contractor identified in the first page of this Bond, including all Contract Documents and changes thereto.

Address of Owner:

**City of Grain Valley, Missouri
711 Main Street
Grain Valley, MO 64029**

Address of Contractor/Principal:

[Insert Name and Address]

Address of Surety:

[Insert Name and Address]

MAINTENANCE BOND

KNOW ALL PERSONS BY THESE PRESENTS: That _____

(Name of Contractor)

(Address of Contractor)

a _____ hereinafter called Principal, and
(Corporation, Partnership, or Individual)

(Name of Surety)

hereinafter called Surety, are held and firmly bound unto _____

(Name of Owner)

(Address of Owner)

hereinafter called OWNER, and unto all persons, firms, and corporations who or which may furnish labor, or who furnish materials to perform as described under the contract and to their successors and assigns in the total aggregate penal sum of _____

_____ Dollars (\$ _____) in lawful money of the United States, for the payment of which sum well and truly to be made, we bind ourselves, our heirs, executors, administrators, successors and assigns, jointly and severally, firmly by these presents.

THE CONDITION OF THIS OBLIGATION is such that, Whereas on the _____ day of _____, 20 ____, the Principal entered into a written agreement with the OWNER, for the construction and reconstruction, or repair of certain public improvements as designated and described in the said agreement; and

Whereas, it was a condition of the contract award by the Owner that these presents be executed by the Principal and Surety aforesaid, and

Whereas, the Principal agrees to guarantee the work hereinabove described, including all materials and workmanship, for the period of one (1) year(s) beginning on the date the Owner so accepts said Work, said date being the formal acceptance date.

NOW, THEREFORE, if the Principal shall and will, in all particulars, well, duly, and faithfully observe, perform and abide by each and every covenant, condition and part of said written agreement and other Contract Documents and shall protect the Owner against all damages, losses and expenses which may occur to Owner, by reason of defective materials used, or by reason of defective workmanship done, and for the construction, reconstruction or repair of said public improvements, and settlement of backfill excavated areas.

IN WITNESS WHEREOF, this instrument is executed in _____ counterparts, each one of which shall be
Number

deemed an original, this the _____ day of _____, 20 ____ .

ATTEST:

(Principal) Secretary

Principal

(SEAL) By _____ (s)

(Witness as to Principal)

(Address)

(Address)

Surety

ATTEST:

(Witness to Surety)

By _____ (s)
Attorney-in-Fact

(Address)

(Address)

NOTE:

1. Date of BOND must not be prior to date of contract.
2. If CONTRACTOR is partnership, all partners should execute BOND.
3. Surety companies executing BONDS must appear on the Treasury Department's most current list (Circular 570 as amended) and be authorized to transact business in the state where the Project is located.
4. Accompany this bond with Attorney-in-Fact's Authority from the Surety Company certified to include the date of the bond.



MISSOURI DEPARTMENT OF
REVENUE
Project Exemption Certificate

This form is to be completed and given to your contractor.

Exempt Entity and Project Information	Name of Exempt Entity Issuing the Certificate		Missouri Tax Exemption Number			
	Address		City		State	ZIP Code
	E-mail Address					
	Project Number	Project Begin Date (MM/DD/YYYY) ____/____/____		Estimated Project End Date (MM/DD/YYYY) ____/____/____		
	Description of Project					
	Project Location			Certificate Expiration Date (MM/DD/YYYY) ____/____/____		
	Provide a signed copy of this certificate, along with a copy of the exempt entity's Missouri Sales and Use Tax Exemption Letter to each contractor or subcontractor who will be purchasing tangible personal property for use in this project. It is the responsibility of the exempt entity to ensure the validity of the information on the certificate. The exempt entity must issue a new certificate if any of the information changes.					
Signature of Authorized Exempt Entity		Printed Name of Authorized Exempt Entity		Date (MM/DD/YYYY) ____/____/____		

Contractor	The Missouri exempt entity named above hereby authorizes the purchase, without sales tax, of tangible personal property to be incorporated or consumed in the construction project identified herein and no other, pursuant to Section 144.062, RSMo . Under penalties of perjury, I declare that the above information and any attached supplement is true, complete, and correct.					
	Name of Purchasing Contractor		Signature of Contractor		Date (MM/DD/YYYY) ____/____/____	
	Address		City		State	ZIP Code

Subcontractor	Contractors - Present this to your supplier in order to purchase the necessary materials tax exempt. Complete the Subcontractor portion if extending the certificate to your subcontractor. The contractor must sign the form in the space provided below.					
	Name of Purchasing Subcontractor					
	Address		City		State	ZIP Code
	Signature of Contractor		Contractor's Printed Name		Date (MM/DD/YYYY) ____/____/____	

Form 5060 (Revised 11-2019)

Taxation Division
P.O Box 358
Jefferson City, MO 65105-0358

Phone: (573) 751-2836
Fax: (573) 522-1666
E-mail: salestaxexemptions@dor.mo.gov

Visit <http://dor.mo.gov/business/sales/sales-use-exemptions.php> for additional information.



Missouri

Division of Labor Standards

WAGE AND HOUR SECTION



MICHAEL L. PARSON, Governor

Annual Wage Order No. 30

Section 048
JACKSON COUNTY

In accordance with Section 290.262 RSMo 2000, within thirty (30) days after a certified copy of this Annual Wage Order has been filed with the Secretary of State as indicated below, any person who may be affected by this Annual Wage Order may object by filing an objection in triplicate with the Labor and Industrial Relations Commission, P.O. Box 599, Jefferson City, MO 65102-0599. Such objections must set forth in writing the specific grounds of objection. Each objection shall certify that a copy has been furnished to the Division of Labor Standards, P.O. Box 449, Jefferson City, MO 65102-0449 pursuant to 8 CSR 20-5.010(1). A certified copy of the Annual Wage Order has been filed with the Secretary of State of Missouri.

Original Signed by _____

Todd Smith, Director
Division of Labor Standards

Filed With Secretary of State: _____ **March 10, 2023**

Last Date Objections May Be Filed: **April 10, 2023**

Prepared by Missouri Department of Labor and Industrial Relations

OCCUPATIONAL TITLE	**Prevailing Hourly Rate
Asbestos Worker	\$68.67
Boilermaker	\$38.37*
Bricklayer	\$60.27
Carpenter	\$61.82
Lather	
Linoleum Layer	
Millwright	
Pile Driver	
Cement Mason	\$55.22
Plasterer	
Communications Technician	\$60.34
Electrician (Inside Wireman)	\$69.22
Electrician Outside Lineman	\$59.91
Lineman Operator	
Lineman - Tree Trimmer	
Groundman	
Groundman - Tree Trimmer	
Elevator Constructor	\$102.69
Glazier	\$58.17
Ironworker	\$68.53
Laborer	\$49.56
General Laborer	
First Semi-Skilled	
Second Semi-Skilled	
Mason	\$54.80
Marble Mason	
Marble Finisher	
Terrazzo Worker	
Terrazzo Finisher	
Tile Setter	
Tile Finisher	
Operating Engineer	\$61.54
Group I	
Group II	
Group III	
Group III-A	
Group IV	
Group V	
Painter	\$50.40
Plumber	\$76.04
Pipe Fitter	
Roofer	\$59.33
Sheet Metal Worker	\$72.78
Sprinkler Fitter	\$75.09
Truck Driver	\$52.39
Truck Control Service Driver	
Group I	
Group II	
Group III	
Group IV	

*The Division of Labor Standards received fewer than 1,000 reportable hours for this occupational title. The public works contracting minimum wage is established for this occupational title using data provided by Missouri Economic Research and Information Center.

**The Prevailing Hourly Rate includes any applicable fringe benefit amounts for each occupational title as defined in RSMO Section 290.210.

Heavy Construction Rates for
JACKSON County

Section 048

OCCUPATIONAL TITLE	**Prevailing Hourly Rate
Carpenter	\$61.98
Millwright	
Pile Driver	
Electrician (Outside Lineman)	\$87.19
Lineman Operator	
Lineman - Tree Trimmer	
Groundman	
Groundman - Tree Trimmer	
Laborer	\$50.25
General Laborer	
Skilled Laborer	
Operating Engineer	\$58.85
Group I	
Group II	
Group III	
Group IV	
Truck Driver	\$50.18
Truck Control Service Driver	
Group I	
Group II	
Group III	
Group IV	

Use Heavy Construction Rates on Highway and Heavy construction in accordance with the classifications of construction work established in 8 CSR 30-3.040(3).

Use Building Construction Rates on Building construction in accordance with the classifications of construction work established in 8 CSR 30-3.040(2).

If a worker is performing work on a heavy construction project within an occupational title that is not listed on the Heavy Construction Rate Sheet, use the rate for that occupational title as shown on the Building Construction Rate Sheet.

*The Division of Labor Standards received fewer than 1,000 reportable hours for this occupational title. Public works contracting minimum wage is established for this occupational title using data provided by Missouri Economic Research and Information Center.

**The Prevailing Hourly Rate includes any applicable fringe benefit amounts for each occupational title.

OVERTIME and HOLIDAYS

OVERTIME

For all work performed on a Sunday or a holiday, not less than twice (2x) the prevailing hourly rate of wages for work of a similar character in the locality in which the work is performed or the public works contracting minimum wage, whichever is applicable, shall be paid to all workers employed by or on behalf of any public body engaged in the construction of public works, exclusive of maintenance work.

For all overtime work performed, not less than one and one-half (1½) the prevailing hourly rate of wages for work of a similar character in the locality in which the work is performed or the public works contracting minimum wage, whichever is applicable, shall be paid to all workers employed by or on behalf of any public body engaged in the construction of public works, exclusive of maintenance work or contractual obligation. For purposes of this subdivision, "**overtime work**" shall include work that exceeds ten hours in one day and work in excess of forty hours in one calendar week; and

A thirty-minute lunch period on each calendar day shall be allowed for each worker on a public works project, provided that such time shall not be considered as time worked.

HOLIDAYS

January first;
The last Monday in May;
July fourth;
The first Monday in September;
November eleventh;
The fourth Thursday in November; and
December twenty-fifth;

If any holiday falls on a Sunday, the following Monday shall be considered a holiday.

Statement of Compliance

(To be submitted with weekly payroll if not using form WH-347)

I hereby certify the following:

- 1) The payroll for the payroll period contains the information required to be provided under § 5.5 (a)(3)(ii) of Regulations, 29 CFR part 5, the appropriate information is being maintained under § 5.5 (a)(3)(i) of Regulations, 29 CFR part 5, and that such information is correct and complete;
- 2) That each laborer or mechanic (including each helper, apprentice, and trainee) employed on the contract during the payroll period has been paid the full weekly wages earned, without rebate, either directly or indirectly, and that no deductions have been made either directly or indirectly from the full wages earned, other than permissible deductions as set forth in Regulations, 29 CFR part 3;
- 3) That each laborer or mechanic has been paid not less than the applicable wage rates and fringe benefits or cash equivalents for the classification of work performed, as specified in the applicable wage determination incorporated into the contract.

Signature of Contractor or Subcontractor

Date



**DIVISION OF
LABOR
STANDARDS**

MISSOURI DEPARTMENT OF LABOR AND INDUSTRIAL RELATIONS
DIVISION OF LABOR STANDARDS

**AFFIDAVIT
COMPLIANCE WITH THE PREVAILING WAGE LAW**

I, _____, upon being duly sworn upon my oath state that: (1) I am the
(Name)
_____ of _____; (2) all requirements of
(Title) *(Name of Company)*
§§ 290.210 to 290.340, RSMo, pertaining to the payment of wages to workers employed on public works projects
have been fully satisfied with regard to this company's work on _____,
(Name of Project)

(3) I have reviewed and am familiar with the prevailing wage rules in 8 CSR 30-3.010 to 8 CSR 30-3.060; (4) based upon my knowledge of these rules, including the occupational titles set out in 8 CSR 30-3.060, I have completed full and accurate records clearly indicating (a) the names, occupations, and crafts of every worker employed by this company in connection with this project together with an accurate record of the number of hours worked by each worker and the actual wages paid for each class or type of work performed, (b) the payroll deductions that have been made for each worker, and (c) the amounts paid to provide fringe benefits, if any, for each worker; (5) the amounts paid to provide fringe benefits, if any, were irrevocably paid to a trustee or to a third party pursuant to a fund, plan, or program on behalf of the workers; (6) these payroll records are kept and have been provided for inspection to the authorized representative of the contracting public body and will be available, as often as may be necessary, to such body and the Missouri Department of Labor and Industrial Relations; (7) such records shall not be destroyed or removed from the state for one year following the completion of this company's work on this project; (8) when in effect, the requirements of §§ 290.550 through 290.580, RSMo, pertaining to excessive unemployment were fully satisfied; and (9) there has been no exception to the full and complete compliance with the provisions and requirements of Annual Wage Order No. _____ Section _____ issued by the Missouri Division of Labor Standards and applicable to this project located in _____ County, Missouri, and completed on the ____ day of _____

The matters stated herein are true to the best of my information, knowledge, and belief. I acknowledge that the falsification of any information set out above may subject me to criminal prosecution pursuant to §§290.340, 570.090, 575.040, 575.050, or 575.060, RSMo.

Signature

Subscribed and sworn to me this ____ day of _____
My commission expires _____.

Notary Public

Receipt by Authorized Public Representative

NOTICE TO PROCEED

Owner: City of Grain Valley, MO

Owner's Contract No.: R24-01

Contractor:

Contractor's Project No.:

Project: 2024 Pavement
Maintenance Program
Asphaltic Concrete Overlay

Contract Name:

Effective Date of Contract:

TO CONTRACTOR:

Owner hereby notifies Contractor that the Contract Times under the above Contract will commence to run on [_____, 2024].

On that date, Contractor shall start performing its obligations under the Contract Documents. No Work shall be done at the Site prior to such date. In accordance with the Agreement, the date of Substantial Completion is _____, and the date of readiness for final payment is _____.

Before starting any Work at the Site, Contractor must comply with the following:

[Note any access limitations, security procedures, or other restrictions]

Owner: City of Grain Valley, Missouri

By: _____
Authorized Signature
Richard J. Tuttle

Title: _____
City Engineer

Date Issued: _____

Copy: Engineer

CONTRACTOR'S AFFIDAVIT AND RELEASE FOR PARTIAL PAYMENT

Application for Payment No.: _____

Application for Payment Application Date: _____

_____ ("Contractor") has entered into a Contract with the City of Grain Valley, Missouri ("Owner") to furnish labor, materials, equipment and services for the construction of improvements located at - _____ ("Project")

For and in consideration of the above-said progress payment under the said Contract, the sufficiency of which is hereby acknowledged, Contractor upon its oath states:

1. Contractor, in making this request for payment, hereby certifies that all work, materials, and services required to date under said Contract have been furnished and that the work has been completed in a satisfactory and workmanlike manner and in compliance with drawings, specifications, instructions and Contract Documents furnished to the Contractor.
2. Contractor also certifies that all work, labor, materials, machinery, and equipment furnished by the Contractor through the date of the last previous Application for payment have been paid for by the Contractor and that there are no amounts unpaid in favor of any subcontractor or materialman or any other person furnishing labor and materials to said Contractor for such period and utilized in the performance of the obligations of the Contractor under the Contract.
3. Contractor warrants and represents that through the date of this Application for Payment it has complied with all applicable laws and requirements of the Contract Documents, including prevailing wage Laws.
4. It is further certified that all amounts, including taxes, required by law or by agreement, to be withheld from employees' wages have been withheld and distributed in the manner provided by law or by the Contract.
5. Except for the amount of retainage, Contractor hereby releases, relinquishes, discharges and waives any and all rights, and claims arising out of labor, services, equipment, and/or materials and supplies ordered, furnished or provided to or in connection with the construction of the Project through the Application for Payment Date stated above, whether such rights or claims arise by virtue of contract, statute, ordinance, regulation, constitution, common law, or otherwise.

CONTRACTOR

BY: _____

(authorized signature)

TITLE: _____

DATE: _____

STATE OF _____)SS

COUNTY OF _____

The undersigned personally appeared before me, is personally known to me to be the _____ of the above-named Contractor, and after being duly sworn, stated that: he/she was and is duly authorized by the above-named Contractor to make the statements, undertakings, warranties, releases, waivers, and discharges contained in the above and forgoing Contractor's Affidavit and Release for Partial Payment; the statements made therein are true and correct; and, he/she executed the same for the purposes and consideration therein expressed.

Subscribed and sworn before me this _____ day of _____, 20____.

Notary Public

My Commission Expires:

CONSENT OF SURETY COMPANY TO FINAL PAYMENT

PROJECT: _____
(Name)

(Street Address)

(City, State, Zip Code)

CONTRACTOR: _____
(Name)

(Street Address)

(City, State, Zip Code)

TO: CITY OF GRAIN VALLEY, MISSOURI
711 MAIN STREET
GRAIN VALLEY, MO 64029
("OWNER")

CONTRACT FOR:

CONTRACT DATE:

In accordance with the provisions of the Contract between City and Contractor as indicated above, the
(here insert name and address of Surety Company as it appears in the bond) _____
_____, SURETY COMPANY,

on bond of (here insert name and address of Contractor as it appears in the bond) _____,
_____, CONTRACTOR,

hereby approves of the final payment to the Contractor, and agrees that final payment to the Contractor shall not relieve the Surety Company of any of its obligations to the Owner as set forth in the said Surety Company's bond.

IN WITNESS WHEREOF,
the Surety Company has hereunto set its hand this _____ day of _____, 20__.

Surety Company

Signature of Authorized Representative

Attest:

(Seal):

Title

CERTIFICATE OF SUBSTANTIAL COMPLETION

DATE OF ISSUANCE _____

PROJECT: _____ PROFESSIONAL: _____

OWNER: City of Grain Valley, MO
711 Main Street
Grain Valley, MO 64029
CONTRACTOR: _____

This Certificate of Substantial Completion applies to all Work under the Contract Documents pursuant to that certain Agreement between Owner and Contractor dated _____. This Certificate of Substantial Completion is hereby issued by Professional to Owner and Contractor.

The Work has been inspected by authorized representatives of Owner and Professional, and the Work is hereby declared to be substantially complete in accordance with the Contract Documents on _____. (DATE OF SUBSTANTIAL COMPLETION).

A tentative list of items to be completed or corrected is attached hereto. This list may not be all-inclusive, and the failure to include an item in it does not alter the responsibility of Contractor to complete all the Work in accordance with the Contract Documents within the time required by the Contract Documents.

The responsibilities between OWNER and CONTRACTOR for security, maintenance, heat, utilities, insurance and other items shall be as follows:

OWNER _____

CONTRACTOR: _____

This certificate does not constitute an acceptance of Work not in accordance with the Contract Documents nor is it a release of Contractor's obligation to complete the Work in strict accordance with the Contract Documents and within the Contract Times.

Issued and Executed by Professional on _____
Date

"Professional"

By: _____
(Authorized Signature)

CONTRACTOR accepts this Certificate of Substantial Completion on _____
Date

"Contractor"

By: _____
(Authorized Signature)

OWNER accepts this Certificate of Substantial Completion on _____
Date

City of Grain Valley, Missouri
"Owner"

By: _____
(Authorized Signature)



LIFE OUTSIDE THE LINES

**GENERAL CONDITIONS
OF THE CONTRACT FOR CONSTRUCTION**

City of Grain Valley, Missouri

711 Main ♦ Grain Valley, MO 64029

Phone: (816) 847-6200 ♦ Fax: (816) 847-6209

TABLE OF CONTENTS

ARTICLE 1 DEFINITIONS AND TERMINOLOGY	1
1.01 Defined Terms	1
1.02 Furnish, Install, Perform, Provide	4
ARTICLE 2 PRELIMINARY MATTERS.....	4
2.01 Delivery of Bonds	4
2.02 Copies of Documents	4
2.03 Before Starting Construction.....	4
2.04 Preliminary Schedules.....	5
2.05 Audio/Video Tape Recordings of Surface.....	5
2.06 Preconstruction Conference	6
2.07 Commencement of Contract Times	6
2.08 Starting the Project.....	6
2.09 Erosion Control.....	6
ARTICLE 3 - CONTRACT DOCUMENTS: INTENT, AMENDING, REUSE	7
3.01 Intent.....	7
3.02 Reference to Standards and Specifications of Technical Societies; Reporting and Resolving Discrepancies ...	7
3.03 Contractor's Representations	7
3.04 Amending Contract Documents.....	8
3.05 Reuse of Documents	8
ARTICLE 4 AVAILABILITY OF LANDS: PHYSICAL CONDITIONS: REFERENCE POINTS	8
4.01 Availability of Lands.....	8
4.02 Subsurface and Physical Conditions	8
4.03 Underground Facilities.....	9
4.04 Reserved	9
4.05 Hazardous Environmental Conditions at Site	9
4.06 Borrow and Waste Sites	10
ARTICLE 5 INSURANCE AND BONDS.....	10
5.01 Contractor's Liability Insurance.....	10
5.02 Commercial General Liability.....	10
5.03 Automobile Liability.....	11
5.04 Workers' Compensation Insurance.....	11
5.05 Miscellaneous Liability Insurance	11
5.06 General Requirements For Liability Insurance Coverages	11
5.07 Property Insurance	13
5.08 Bonds	14
ARTICLE 6 CONTRACTOR'S RESPONSIBILITY	14
6.01 General.....	14
6.02 Supervision.....	14
6.03 Labor and Construction Procedures	14
6.04 Materials and Equipment.....	16
6.05 Quality of Materials and Equipment.....	17
6.06 Schedule.....	17
6.07 "Or-Equal" Items	17
6.08 Substitutions.....	18
6.09 Concerning Subcontractors, Suppliers and Others.....	19
6.10 Patent Fees and Royalties.....	20
6.11 Permits and Fees	20
6.12 Laws and Regulations	20
6.13 Prevailing Wage Rates	20
6.14 Taxes.....	21
6.15 Use of Premises	22
6.16 Site Cleanup.....	22
6.17 Loading of Structures	22
6.18 Record Documents	22
6.19 Safety and Protection	22
6.20 Safety Representative	23
6.21 Emergencies.....	23
6.22 Submittals.....	23
6.23 Contractor's Warranty.....	24
6.24 Continuing the Work	25
6.25 Indemnification	25
6.26 Survival of Obligations.....	26

ARTICLE 7 OTHER WORK	26
7.01 Related Work at Site.....	26
7.02 Coordination	26
7.03 Liability.....	27
ARTICLE 8 OWNER'S RESPONSIBILITIES	27
8.01 Termination of Professional	27
8.02 Data and Information	27
8.03 Limitations on Owner's Responsibilities	27
ARTICLE 9 PROFESSIONAL'S STATUS DURING CONSTRUCTION	27
9.01 General.....	27
9.02 Visits to Site.....	28
9.03 Project Representation	28
9.04 Clarifications and Interpretations	28
9.05 Authorized Variations in Work	28
9.06 Rejecting Defective Work	28
9.07 Submittals.....	28
9.08 Change Orders	28
9.09 Payments.....	28
9.10 Determinations for Unit Prices	28
9.11 Limitations on Professional's Responsibilities	28
9.12 Terminology.....	29
ARTICLE 10 CHANGES IN THE WORK AND CLAIMS.....	29
10.01 Authorized Changes in Work	29
10.02 Unauthorized Changes in Work.....	29
10.03 Notice to Surety	29
10.04 Claims.....	29
ARTICLE 11 CHANGE OF CONTRACT PRICE	30
11.01 Contract Price.....	30
11.02 Change.....	30
11.03 Determination of Adjustment	30
11.04 Cost of the Work.....	30
11.05 Costs Excluded.....	31
11.06 Contractor's Fee	32
11.07 Submission of Itemized Costs	32
11.08 Allowance	32
ARTICLE 12 CHANGE OF CONTRACT TIMES.....	33
12.01 Claims for Additional Time	33
12.02 Delays of Contract Times	33
12.03 Delay Damages	33
12.04 Liquidated Damages.....	34
ARTICLE 13 TESTS AND INSPECTIONS; CORRECTION, REMOVAL OR ACCEPTANCE OF DEFECTIVE WORK.....	34
13.01 Access to Work.....	34
13.02 Tests and Inspections.....	34
13.03 Uncovering Work	34
13.04 Owner May Stop the Work.....	35
13.05 Correction or Removal of Defective Work.....	35
13.06 Guarantee Period	35
13.07 Acceptance of Defective Work.....	35
13.08 Owner May Correct Defective Work	36
ARTICLE 14 PAYMENTS TO CONTRACTOR AND COMPLETION	36
14.01 Contract Price.....	36
14.02 Basis Of Progress Payments	36
14.03 Applications For Payment.....	36
14.04 Approval For Payment.....	37
14.05 Decisions To Withhold Approval.....	37
14.06 Progress Payments	38
14.07 Failure Of Payment.....	38
14.08 Substantial Completion.....	38
14.09 Partial Occupancy Or Use	39
14.10 Final Completion And Final Payment	39

ARTICLE 15 SUSPENSION OF WORK AND TERMINATION	40
15.01 Termination by Owner for Cause	40
15.02 Notice of Termination.....	40
15.03 Suspension by the Owner for Convenience.....	41
15.04 Owner's Termination For Convenience	41
ARTICLE 16 DISPUTE RESOLUTION	42
16.01 Methods and Procedures.....	42
16.02 Continuing Performance	42
16.03 Exceptions	42
ARTICLE 17 MISCELLANEOUS.....	42
17.01 Notice	42
17.02 Rights and Remedies	43
17.03 Buy American Requirements	43
17.04 Successors and Assigns.....	43
17.05 Records	43
17.06 General.....	43

GENERAL CONDITIONS

ARTICLE 1 – DEFINITIONS AND TERMINOLOGY

1.01 Defined Terms

A. Wherever used in these General Conditions or in the other Contract Documents the following terms have the meanings indicated which are applicable to both the singular and plural thereof:

1. Abbreviations - Wherever in these specifications and Contract Documents the following abbreviations are used, they shall be the latest year of adoption or revision, unless otherwise specified:

A.A.S.H.T.O.	American Association of State Highway and Transportation Officials
A.C.I.	American Concrete Institute
A.I.S.C.	American Institute of Steel Construction
A.P.W.A. Association	Kansas City Metropolitan Chapter of the American Public Works Association
A.R.E.A.	American Railway Professionaling Association
A.S.T.M.	American Society for Testing and Materials
A.W.S.	American Welding Society
A.W.W.A.	American Water Works Association
C.R.S.I.	Concrete Reinforcing Steel Institute
M.C.I.B.	Midwest Concrete Industry Board, Inc.
MoDOT	Missouri Highway and Transportation Department
M.S.S.H.C.	Missouri Standard Specifications for Highway Construction
U.S.A.S.I.	United States of America Standards Institute
U.B.C.	Uniform Building Code
B.O.R.	Board of Outdoor Recreation
I.S.S.A	International Slurry Surfacing Association

2. Addenda - Written or graphic instruments issued prior to the opening of Bids which clarify, correct or change the Bidding Documents or the Contract Documents.

3. Agreement - The written agreement between Owner and Contractor covering the Work to be performed; other Contract Documents are attached to or referred to in the Agreement and are made a part thereof as provided therein.

4. Application for Payment - The form provided by Owner which is to be used by Contractor in requesting progress or final payments and which is to include such supporting documentation as is required by the Contract Documents.

5. Asbestos - Any material that contains more than one percent asbestos and is friable or is releasing asbestos fibers into the air above current action levels established by the United States Occupational Safety and Health Administration.

6. Bonds - Performance and Payment Bonds and any other instruments of security.

7. Change Order - Contractor's and Owner's and agreement with respect to an addition, deletion or revision in the Work, or an adjustment in the Contract Price or the Contract Times, issued on or after the Effective Date of the Agreement, as set forth in Paragraph 10.01 B.

8. Contract Documents - The Agreement, all Addenda which pertain to the Contract Documents, and identified in the Agreement, the Bonds, these General Conditions, the Supplementary Conditions, if any, the Specifications and the Drawings as the same are more specifically identified in the Agreement, any other document identified in the Agreement as part of the Contract Documents, and Modifications issued after execution of the Agreement. A Modification is: (a) a written amendment to the Contract signed by both parties; (b) a Change Order, or; (c) a Field Order. Shop Drawings, Submittals and reports and drawings of subsurface and physical conditions identified in Exhibit A to the Agreement are not Contract Documents.

9. Contract - The Contract Documents form the Contract. The Contract represents the entire and integrated agreement between the parties hereto and supersedes prior representations or agreements, either written or oral. The Contract may be amended or modified only by a written Modification defined above. The Contract Documents shall not be construed to create a contractual relationship of any kind between the Owner and a Subcontractor or any lower-tier Subcontractor of any tier or a Supplier.

10. Contract Price - The moneys payable by Owner to Contractor under the Contract Documents as stated in the Agreement.
11. Contract Times - The number of calendar days, or the completion dates stated in the Agreement: (i) to achieve Substantial Completion, and (ii) to achieve Final Completion.
12. Contractor - The person, firm, or corporation, with whom Owner has entered into the Agreement.
13. Day - a calendar day of 24 hours measured from midnight to the next midnight.
14. Defective - An adjective which when modifying the word Work refers to Work that is unsatisfactory, faulty or deficient, or does not conform to the Contract Documents, or does not meet the requirements of any inspection, reference standard, test or approval referred to in the Contract Documents, or has been damaged prior to Professional's recommendation of final payment.
15. Drawings - The drawings which show the character and scope of the Work to be performed and which have been prepared or provided by Professional and are referred to in the Contract Documents. Shop drawings are not Drawings as so defined.
16. Effective Date of the Agreement - The date indicated in the Agreement on which it becomes effective, but if no such date is indicated it means the date on which the Agreement is signed and delivered by the last of the two parties to sign and deliver.
17. Field Order - A written order issued by Professional or Owner which orders minor changes in the Work in accordance with Paragraph 10.01 E. but which does not involve a change in the Contract Price or the Contract Times.
18. Final Completion - Final Completion shall mean the date upon which the Professional certifies that the Work has been completed in strict accordance with the terms and conditions of the Contract Documents, including all Punch List items, that all documents and information required by the Contract Documents have been submitted to Owner by Contractor and that the entire balance of the Contract Price is due and payable to Contractor.
19. General Requirements - Section VII of the Contract Documents. The General Requirements pertain to all sections of the Specifications.
20. Hazardous Waste - The term Hazardous Waste shall have the meaning provided in Section 1004 of the Solid Waste Disposal Act (42 USC Section 6903) as amended from time to time.
21. Laws and Regulations- Any and all applicable laws, rules, regulations, ordinances and codes and interpretations thereof and any orders of any and all governmental bodies, agencies, authorities and courts having jurisdiction.
22. Liens - Liens, charges, security interests or encumbrances upon real property, Project funds or personal property.
23. Lump Sum Price Contract - A lump sum price contract is a contract for which compensation for the Work is based on one lump sum amount without regard to any units or portions of the Work accomplished.
24. Notice of Award - The written notice by Owner to the apparent successful bidder stating that upon compliance by the apparent successful Bidder with the conditions precedent enumerated therein, within the time specified, Owner will sign and deliver the Agreement.
25. Notice to Proceed - A written notice given by Owner to Contractor fixing the date on which the Contract Times will commence to run and on which Contractor shall start to perform Contractor's obligations under the Contract Documents.
26. Owner - The City of Grain Valley, Missouri with whom Contractor has entered into the Agreement and for whom the Work is to be provided.
27. Partial Utilization - Placing a portion of the Work in service for the purpose for which it is intended (or a related purpose) before reaching Substantial Completion for all the Work.
28. PCBs - Polychlorinated biphenyls.
29. Pavement - Rigid or flexible type riding surface placed upon a previously prepared Sub-grade or base.

30. Petroleum - Petroleum, including crude oil or any fraction thereof which is liquid at standard conditions of temperature and pressure (60 degrees Fahrenheit and 14.7 pounds per square inch absolute), such as oil, petroleum, fuel oil, oil sludge, oil refuse, gasoline's, kerosene, and oil mixed with other non-Hazardous Wastes and crude oils.
31. Product Data - Illustrations, standard schedules, performance charts, instructions, brochures, diagrams and other information furnished by the Contractor to illustrate materials or equipment for some portion of the Work.
32. Professional - The person, firm or corporation named as such in the Agreement.
33. Project - The total construction of which the Work to be provided under the Contract Documents may be the whole or a part as indicated elsewhere in the Contract Documents.
34. Punch List - The list of items, prepared in connection with the inspection of the Project by the Professional in connection with Substantial Completion of the Work or a portion of the Work, which the Owner's Representative or Professional has designated as remaining to be performed, completed or corrected before the Work will be accepted by the Owner.
35. Radioactive Material - Source, special nuclear, or byproduct material as defined by the Atomic Energy Act of 1954 (42 USC Section 2011 et seq.) as amended from time.
36. Resident Project Representative - The authorized representative of Professional who is assigned to the Project site or any part thereof.
37. Samples - Physical examples of materials, equipment or workmanship that are representative of some portion of the Work and which establish the standards by which such portion of the Work will be judged.
38. Site - Lands or areas indicated in the Contract Documents as being furnished by Owner which are designated for the use of the Contractor.
39. Shop Drawings - All drawings, diagrams, illustrations, performance charts, instructions, brochures, schedules and other data which are specifically prepared by or for Contractor to illustrate some portion of the Work.
40. Specifications - Those portions of the Contract Documents consisting of written technical descriptions of materials, equipment, construction systems, standards and workmanship as applied to the Work and certain administrative details applicable thereto.
41. Standard Specifications - The officially adopted "Standard Specifications" as adopted by the Owner.
42. Subcontractor - Any individual or entity having a direct contract with Contractor for the performance of the Work at the Site or any person or entity having a contract with a Subcontractor or any lower tier Subcontractor for the performance of part of the Work at the Site.
43. Street, Road or Alley - The whole area within the right-of-way limits.
44. Sub-Grade - That portion of the construction area which has been prepared as specified and upon which a layer of specified material, base, sub-base course, pavement, or other improvement is to be placed.
45. Substantial Completion - The Work (or a specified part thereof) has progressed to the point where, in the opinion of Professional as evidenced by Professional's definitive certificate of Substantial Completion, it is sufficiently complete, in accordance with the Contract Documents, so that the Work (or specified part) can be utilized for the purposes for which it is intended and Owner has obtained any approvals, permits or certificates of occupancy from any applicable governmental entity or agency so that the Work can be utilized for its intended purposes. The terms "substantially complete" and "substantially completed" as applied to any Work refer to Substantial Completion thereof.
46. Supplementary Conditions - The part of the Contract Documents which amends or supplements these General Conditions.
47. Supplier - A manufacturer, fabricator, distributor, material man or vendor having a direct contract with Contractor or with any Subcontractor or with any lower tier Subcontractor to furnish materials or equipment to be incorporated in the Work.

48. Underground Facilities - All pipelines, conduits, ducts, cables, wires, manholes, vaults, tanks, tunnels or other such facilities or attachments, and any encasements containing such facilities which have been installed underground to furnish any of the following services or materials: electricity, gases, steam, liquid petroleum products, telephone or other communications, cable television, sewage and drainage removal, traffic or other control systems or water.

49. Unit Price Work - Work to be paid for on the basis of unit prices.

50. Work - The supervision, labor, equipment, tools, material, supplies, incidentals, operations and activities required by the Contract Documents or reasonably inferable by Contractor therefrom as necessary to produce the results intended by the Contract Documents in a safe, expeditious, orderly, and workmanlike manner, and in the best manner known to each respective trade. The Work may constitute the whole or part of the Project.

51. Work Change Directive - A written directive to Contractor, issued on or after the Effective Date of Agreement and signed by Owner and approved by Professional, ordering an addition, deletion or revision in the Work, or responding to differing or unforeseen physical conditions under which the Work is to be performed as provided in Sections 4.02 or 4.03 or to emergencies under Paragraph 6.21. A Work Change Directive will not change the Contract Price or the Contract Times, but is evidence that the parties expect that the change directed or documented by a Work Change Directive will be incorporated in a subsequently issued Change Order following negotiations by the parties as to its effect, if any, on the Contract Price or Contract Times as provided in Article 10.

52. Written Amendments - A written amendment of the Contract Documents, signed by Owner and Contractor on or after the Effective Date of the Agreement and normally dealing with the non-engineering or non-technical matters rather than strictly construction-related aspects of the Contract Documents.

1.02 Furnish, Install, Perform, Provide

A. The word "furnish," when used in connection with services, materials, or equipment, shall mean to supply and deliver said services, materials, or equipment to the Site ready for use or installation and in usable or operable condition.

B. The word "install," when used in connection with services, materials, or equipment, shall mean to put into use or place in final position said services, materials, or equipment complete and ready for intended use.

C. The words "perform" or "provide," when used in connection with services, materials, or equipment, shall mean to furnish and install said services, materials, or equipment complete and ready for intended use.

D. When "furnish," "install," "perform," or "provide" is not used in connection with services, materials, or equipment in a context clearly requiring an obligation of Contractor, "provide" is implied.

ARTICLE 2 - PRELIMINARY MATTERS

2.01 Delivery of Bonds

A. When Contractor delivers the executed Agreement to Owner, Contractor shall also deliver to Owner such Bonds as Contractor is required to furnish by the Contract Documents.

2.02 Copies of Documents

A. Owner shall furnish to Contractor up to five (5) copies of the Contract Documents as are reasonably necessary for the execution of the Work. Additional copies will be furnished, upon request, at the cost of reproduction.

2.03 Before Starting Construction

A. Since the Contract Documents are complimentary, before starting each portion of the Work, the Contractor shall carefully study and compare the various Drawings and other Contract Documents relative to that portion of the Work, as well as the information furnished by the Owner, shall take field measurements of any existing conditions related to that portion of the Work and shall observe any conditions at the Site affecting it. These obligations are for the purpose of facilitating construction by the Contractor; however, any errors, inconsistencies or omissions discovered by the Contractor shall be reported promptly to the Professional as a request for information in such form as the Professional may require. Contractor shall not be liable to Owner or Professional for failure to report

any error, inconsistencies or omissions in the Contract Documents, unless Contractor had actual knowledge thereof or should reasonably have known thereof.

B. Any design error, inconsistencies or omissions noted by the Contractor during any review of the Contract Documents shall be reported promptly to the Professional.

C. If the Contractor believes that additional cost or time is involved because of clarifications or instructions issued by the Professional in response to the Contractor's notices or requests for information pursuant to Subparagraphs 2.03 A. or 2.03 B., the Contractor shall make Claims as provided in Articles 11 and/or 12. If the Contractor fails to perform the obligations of Subparagraphs 2.03 A. or 2.03 B., the Contractor shall pay such costs and damages to the Owner as would have been avoided if the Contractor had performed such obligations.

D. Before any Work at the site is started, Contractor shall deliver to Owner, with a copy to Professional, certificates (and other evidence of insurance requested by Owner) which Contractor is required to purchase and maintain in accordance with Sections 5.01, 5.02, 5.03, 5.04, 5.05 and 5.06 and 5.07.

2.04 Preliminary Schedules

A. Within ten (10) days after the Effective Date of the Agreement (unless otherwise specified in the General Requirements) Contractor shall submit to Professional for its timely review: (a) a preliminary construction schedule; and (b) a preliminary schedule for Submittals which will list each required submittal and the times for submitting, reviewing, and process such Submittals. The construction schedule shall be in a detailed format satisfactory to the and the Professional which shall also: (1) provide a graphic representation of all activities and events that will occur during performance of the Work; (2) identify each phase of construction and occupancy; and (3) set forth dates that are critical in ensuring the timely and orderly completion of the Work in accordance with the requirements of the Contract Documents (hereinafter referred to as Milestones). If Professional has a reasonable objection to the construction schedule or schedule for Submittals by Contractor, the construction schedule shall be promptly revised by the Contractor in accordance with the recommendations of the Professional and re-submitted for acceptance. Such acceptance will not impose on Professional or Owner responsibility for the construction schedule or schedule for Submittals, schedule, for sequencing, scheduling or progress of the Work nor interference with or relieve Contractor from Contractor's full responsibility thereof.

2.05 Audio/Video Tape Recordings of Surface

A. Before starting the Work, the Contractor shall record the following surface conditions in audio and video form in the presence of the Professional and Owner in the following means:

1. The following location information shall be provided on color audio/video tape recording while walking the construction route.

a. Audio: Each recording shall begin with a verbal description of the current date, project name and municipality and be followed by the general location, (i.e., name of street, viewing side and direction of progress).

b. Video: Transparent information must appear on the viewing screen. This information will consist of the date and time of recording. The date information will contain the month, day and year.

c. Digital: To preclude the possibility of tampering or editing in any manner, all video recordings must, by electronic means, display continuously and simultaneously generated transparent digital information to include the date and time of recording. The date information will contain the month, day and year.

2. The taped coverage shall include all surface features located within the zone of influences of construction supported by appropriate audio description. Audio description shall be made simultaneously with video coverage. Such coverage shall include, but not be limited to, all existing driveways, sidewalks, fences, curbs, ditches, roadways, landscaping, trees, culverts, headwalls, retaining walls, or buildings located within such zone of influence. Particular and detailed attention shall be given to any defects noted, such as cracks, disturbed areas, damaged items, or as may be required by the Professional. It is the intent of this coverage to accurately and clearly document pre-existing conditions and especially any items that could result in construction claims. **The excavation areas shall be physically marked with high visibility fluorescent paint prior to video taping. The markings shall include the job number and stationing.**

3. The zone of influence shall be defined as an area within 30 feet of the proposed work, and an additional 20 feet of supplemental coverage shall be provided in residential areas.

4. The Contractor shall be able to televise and tape areas with paved roads, along co-owned easements through parks, lawns, and open fields. If video taping on private property, the Contractor shall give the Owner sufficient prior notice of such entry so that property owners may be advised of and their permission obtained for the work.

5. To produce the proper detail and perspective, adequate lighting will be required to fill in the shadow areas caused by trees, utility poles, road signs and other such objects in residential areas or as directed by the Professional.

6. Houses and buildings shall be identified visually by house number, when visible, in such a manner that structures of the proposed system, (i.e., manholes on a sewer system and hydrants on a water system), can be located by reference.

7. Panning rates and zoom-in, zoom-out rates shall be controlled sufficiently such that during playback will produce clarity of the object viewed. The playback picture shall be in focus and be of extreme clarity at all times.

8. All taping shall be done during times of good visibility. No taping shall be done during periods of visible precipitation, or when more than 10% of the ground area is covered with snow, unless otherwise authorized by the Professional.

9. Professional shall have the authority to designate what areas may be omitted or added for audio-video coverage.

10. All tapes (cassettes and cases) shall be properly identified by tape number, location and project name and municipality in a manner acceptable to the Professional.

11. A record of the contents of each tape shall be supplied by a run sheet identifying each segment in the tape by location, i.e., roll number, street or road viewing, tape counter number, viewing side, point starting from, traveling direction and ending destination point.

12. Any portion of the video tape recording not conforming to specifications shall be rejected.

13. Any taped coverage not acceptable to the owner shall be re-filmed at no additional charge. The Contractor shall reschedule unacceptable coverage five (5) days after being notified.

14. One original and two copies are to be provided. Original to Owner, one copy to Professional, and one copy to Contractor.

15. Payment will be at the contract lump sum price for Video Documentation which price shall include all labor, equipment, and materials necessary to complete the work.

16. The taping shall be performed while a representative of the City and Professional is present. The City shall be notified a minimum of 48 hours in advance.

2.06 Preconstruction Conference

A. Within twenty (20) days after the Effective Date of the Agreement, but before Contractor starts the Work at the site, a conference attended by Contractor, Professional and others as appropriate will be held to discuss the schedules referred to in Section 2.04, to discuss procedures for handling Shop Drawings and other submittals and for processing Applications for Payment, and to establish a working understanding among the parties as to the Work.

2.07 Commencement of Contract Times

A. The Contract Times will commence to run on the day indicated in the Notice to Proceed. A Notice to Proceed may be given at any time within thirty (30) days after the Effective Date of the Agreement.

2.08 Starting the Project

A. Contractor shall start to perform the Work on the date when the Contract Times commence to run, but no Work shall be done at the Site prior to the date on which the Contract Times commence to run.

2.09 Erosion Control

A. Contractor shall submit an erosion control plan for approval and shall implement the approved plan prior to any Work being performed.

ARTICLE 3 - CONTRACT DOCUMENTS: INTENT, AMENDING, REUSE

3.01 Intent

A. The Contract Documents comprise the entire agreement between Owner and Contractor concerning the Work. The Contract Documents are complimentary; what is called for by one is as binding as if called for by all.

B. It is the intent of the Contract Documents to describe a functionally complete Project (or part thereof) to be constructed in accordance with the Contract Documents. Any Work, materials or equipment that may reasonably be inferred from the Contract Documents or from prevailing custom or trade usage as being required to produce the intended result will be furnished and performed whether or not specifically called for at no additional cost to Owner. When words or phrases which have a well-known technical or construction industry or trade meaning are used to describe Work, materials or equipment, such words or phrases shall be interpreted in accordance with that meaning. Clarifications and interpretations of the Contract Documents shall be issued by Professional.

3.02 Reference to Standards and Specifications of Technical Societies; Reporting and Resolving Discrepancies

A. Reference to standard specifications, manuals or codes of any technical society, organization or association, or to the Laws or Regulations of any governmental authority, whether such reference be specific or by implication, shall mean the latest standard specification, manual, code or Laws or Regulations in effect at the time of opening of Bids, except as may be otherwise specifically stated in the Contract Documents.

B. No provision of any referenced standard specification, manual or code (whether or not specifically incorporated by reference in the Contract Documents) shall be effective to change the duties and responsibilities of Owner, Contractor or Professional, or any of their consultants, agents or employees from those set forth in the Contract Documents, nor shall it be effective to assign to Professional or Owner, or any of Professional's or Owner's consultants, agents or employees, any duty or authority to supervise or direct the furnishing or performance of the Work or any duty or authority to undertake responsibility contrary to the provisions of the Contract Documents.

C. Except as otherwise specifically stated in the Contract Documents or as may be provided by a modification, the provisions of the Contract Documents shall take precedence in resolving any conflict, error, ambiguity or discrepancy between the provisions of the Contract Documents and:

1. the provisions of any standard, specification, manual, code or instruction (whether or not specifically incorporated by reference in the Contract Documents); or
2. the provisions of any such Laws or Regulations applicable to the performance of the Work (unless such an interpretation of the provisions of the Contract Documents would result in violation of such Law or Regulation).

D. Drawings are intended to show general arrangements, design, and dimensions of the Work and are partly diagrammatic. Dimensions shall not be determined by scale or rule. If figured dimensions are lacking, they shall be supplied by the Professional on the Contractor's written request to the Professional. Where, on any Drawings, a portion of the Work is drawn out and the remainder is indicated in outline, the parts drawn out shall apply also to all other like portions of the Work. Where ornaments or other details are indicated by starting only, such details shall be continued throughout the courses or parts in which they occur and shall also apply to all other similar parts in the Work, unless otherwise indicated. In case of differences between small and large scale drawings, the larger scale drawings shall govern.

3.03 Contractor's Representations

A. Except as to any reported errors, inconsistencies or omissions, by executing the Contract, the Contractor represents the following:

1. The Contract Documents are sufficiently complete and detailed for the Contractor to (a) perform the Work required to produce the results intended by the Contract Documents and (b) comply with all the requirements of the Contract Documents; and
2. The Work required by the Contract Documents, including, without limitation, all construction details, construction means, methods, procedures and techniques necessary to perform the Work, use of materials, selection of equipment and requirements of product manufacturers are consistent with: (a) good and sound practices within the construction industry; (b) generally prevailing and accepted industry standards applicable to the Work; (c) requirements of any warranties applicable to the Work; and (d) all laws, ordinances, regulations, rules and orders which bear upon the Contractor's performance of the Work.

B. Execution of the Agreement by the Contractor is a representation that the Contractor has visited the site, become familiar with local conditions under which the Work is to be performed and correlated personal observations with requirements of the Contract Documents. Contractor represents that it has performed its own

investigation and examination of the Project site and its surroundings and satisfied itself before entering into this Contract as to:

1. conditions bearing upon transportation, disposal, handling and storage of materials;
2. the availability of labor, materials, equipment, water, electrical power, utilities and roads;
3. uncertainties of weather, river stages, flooding and similar characteristics of the site;
4. conditions bearing upon security and protection of material, equipment and Work in progress;
5. the form and nature of the Project site, including the surface and sub-surface conditions;
6. the extent and nature of Work and materials necessary for the execution of the Work and the remedying of any defects therein; and
7. the means of access to the site and the accommodations it may require and, in general, shall be deemed to have obtained all information as to risks, contingencies and other circumstances.

3.04 Amending Contract Documents

A. The Contract Documents may be amended only by a Modification.

3.05 Reuse of Documents

A. Neither Contractor nor any Subcontractor, Supplier, other person or organization performing or furnishing any of the Work under a direct or indirect contract with Owner shall have or acquire any title to or ownership rights in any of the Drawings, Specifications or other documents (or copies of any thereof). They shall not reuse any of them on extensions of the Project or any other project without written consent of Owner and specific written verification or adaptation by the Professional who prepared the documents. This prohibition shall survive final payment, completion, acceptance of the Work, or termination or completion of the Contract. Nothing contained herein shall preclude Contractor from retaining copies of the Contract Documents for record purposes.

ARTICLE 4 - AVAILABILITY OF LANDS: PHYSICAL CONDITIONS: REFERENCE POINTS

4.01 Availability of Lands

A. Contract Times Owner shall obtain all lands and rights-of-way upon which the Work is located prior to the issuance of a notice to proceed, except as set forth in the Contract Documents. In the event Owner is unable to acquire all lands and rights-of-way prior to the issuance of the notice to proceed, Owner shall notify the Contractor of which lands and rights-of-way have not been obtained and will proceed with Work only upon lands and rights-of-way Owner has obtained. The Contractor recognizes this risk and this contingency has been included in the Contract Price. Owner, with reasonable promptness, shall obtain the lands and rights-of-way upon which the Work is located. In no event will the Contractor be entitled to monetary compensation for Owner's reasonable delay in obtaining the lands or rights-of-way, since this contingency has been included in the Contract Price. The Contractor's sole recovery will be in the form of an extension of time, if appropriate. Contractor shall provide for all additional lands and access thereto that may be required for temporary construction facilities or storage of materials and equipment.

4.02 Subsurface and Physical Conditions

A. If conditions are encountered at the site which are (1) subsurface or otherwise concealed physical conditions, other than Underground Facilities, which differ materially from those indicated in the Contract Documents, or (2) unknown physical conditions, other than Underground Facilities, of an unusual nature, which differ materially from those ordinarily found to exist and generally recognized as inherent in construction activities of the character provided for in the Contract Documents, then notice by the Contractor shall be given to the Professional promptly before conditions are disturbed, and in no event later than three (3) days after first observance of the conditions. The Professional will promptly investigate such conditions. If such conditions differ materially, as provided for above and cause an increase or decrease in the Contractor's cost of, or time required for performance of the Work, an equitable adjustment in the Contract Price or Contract Times, or both, shall be made, subject to the provisions and restrictions set forth herein. If Professional determines that the conditions at the site are not materially different from those indicated in the Contract Documents, and that no change in the terms of the Contract is justified, Professional will so notify the Contractor in writing. If the Contractor disputes the finding of the Professional that no change in the terms of the Contract is justified, Contractor shall proceed with the Work, taking whatever steps are necessary to overcome or correct such conditions so that Contractor can proceed in a timely manner. The Contractor shall have the right to file a Claim in accordance with the Contract Documents.

B. It is expressly agreed that no adjustment in the Contract Times or Contract Price shall be permitted, however, in connection with a concealed or unknown condition which does not differ materially from those conditions

disclosed or which reasonably should have been disclosed by the Contractor's (1) prior inspections, tests, reviews and preconstruction investigations for the Project, or (2) inspections, tests, reviews and preconstruction inspections which the Contractor had the opportunity to make or should have performed in connection with the Project. The Owner assumes no responsibility for any conclusions or interpretations based upon information relating to sub-surface or other site conditions made available by the Owner, and marked "for informational purposes only." The Owner and Professional do not warrant the accuracy of any information relating to sub-surface conditions contained in reports, documents and drawings made available to Contractor marked "for informational purposes only" and such documents are not Contract Documents. Contractor may not rely upon the accuracy or completeness of such reports and drawings and should perform its own tests and investigations of the same. Contractor shall make no claim against the Owner or Professional for any inaccuracy of such information, reports, documents or drawings, including any Claim that the physical conditions are different than those indicated in such reports and drawings.

4.03 Underground Facilities

A. The information and data shown or indicated in the Contract Documents with respect to existing Underground Facilities at or contiguous to the site is based on information and data furnished to Owner or Professional by the Owners of such Underground Facilities or by others. Unless it is otherwise expressly provided in the Supplementary Conditions:

1. Owner and Professional shall not be responsible for the accuracy or completeness of any such information; and
2. Contractor shall have full responsibility for reviewing and checking all such information and data, locating all Underground Facilities shown or indicated in the Contract Documents, coordination of the Work with the Owners of such Underground Facilities during construction, the safety and protection thereof as provided in Paragraph 6.21 and repairing any damage thereto resulting from the Work, the cost of all of which will be considered as having been included in the Contract Price.

B. If an Underground Facility is uncovered or revealed at or contiguous to the site which was not shown or indicated in the Contract Documents and which Contractor could not reasonably have been expected to be aware of, Contractor shall, promptly after becoming aware thereof and before performing any Work affected thereby (except in an emergency as permitted by Paragraph 6.21) identify the Owner of such Underground Facility and give written notice thereof to that Owner and to Owner and Professional.

1. Professional will promptly review the Underground Facility to determine the extent to which the Contract Documents should be modified to reflect and document the consequences of the existence of the Underground Facility, and the Contract Documents will be amended or supplemented to the extent necessary. During such time, Contractor shall be responsible for the safety and protection of such Underground Facility as provided in Article 6.20.
2. Contractor shall be allowed an increase in the Contract Price or an extension of the Contract Times, or both, to the extent that they are attributable to the existence of any Underground Facility that was not shown or indicated in the Contract Documents and which Contractor could not reasonably have been expected to be aware of. If the parties are unable to agree as to the amount or length thereof, Contractor may make a claim therefor as provided in Articles 11 and 12.

4.04 Reserved

4.05 Hazardous Environmental Conditions at Site

A. Contractor shall not be responsible for any Asbestos, PCBs, Petroleum, Hazardous Waste or Radioactive Material uncovered or revealed at the site which was not shown or indicated in Drawings or Specifications or identified in the Contract Documents to be within the scope of the Work and which may present a substantial danger to persons or property exposed thereto in connection with the Work at the Site. Contractor shall be responsible for any such materials brought to the site by Contractor, Subcontractor, Suppliers or anyone else for whom Contractor is responsible.

B. Contractor shall immediately: (1) stop all Work in connection with such hazardous condition and in any area affected thereby (except in an emergency as required by Paragraph 6.21), and (2) notify Owner and Professional (and thereafter confirm such notice in writing). Owner shall promptly consult with Professional concerning the necessity for Owner to retain a qualified expert to evaluate such hazardous condition or take corrective action, if any. Contractor shall not be required to resume Work in connection with such hazardous condition or in any such affected area until after Owner has obtained any required permits related thereto and delivered to Contractor special written notice: (a) specifying that such condition and any affected area is or has been rendered safe for the resumption of Work, or (b) specifying any special conditions under which such Work may be resumed safely. If Owner and Contractor cannot agree as to entitlement to or the amount or extent of any

adjustment, if any, in Contract Price or Contract Times as a result of such work stoppage or such special conditions under which Work is agreed by Contractor to be resumed, Contractor may make a claim therefor as provided in Articles 11 and 12.

C. If after receipt of such special written notice Contractor does not agree to resume such Work based on a reasonable belief it is unsafe, or does not agree to resume such Work under such special conditions, the Owner may order such portion of the Work that is in connection with such hazardous condition or in such affected area to be deleted from the Work. If Owner and Contractor cannot agree as to entitlement to or the amount or extent of any adjustment, if any, in Contract Price or Contract Times as a result of deleting such portion of the Work, then either party may make a claim therefor as provided in Articles 11 and 12. Owner may have such deleted portion of the Work performed by Owners' own forces or others in accordance with Article 7.

D. It is acknowledged and agreed by Contractor that in no event shall Owner have any responsibility for any substance or material that is brought to the Project site by the Contractor, any Subcontractor of any tier, any materialman, Supplier or any person or entity for whom any of them is responsible. If Contractor brings to the Project site any hazardous material, toxic material or any material regulated by any Laws, Contractor shall notify Professional in writing and Contractor shall comply with all applicable Laws relating thereto and accept sole responsibility for compliance with all environmental quality standards, limitations and permit requirements promulgated thereunder, including without limitation federal, state and local air quality standards for fugitive dust control, prevention of surface and ground water contamination and hazardous and other waste disposal practices and procedures. Contractor shall utilize the highest degree of care in handling such materials and in taking all necessary precautions and measures to prevent any spills of such materials. The Contractor shall defend, indemnify and hold harmless the Owner from any and all claims, costs, losses, damages and expenses, including reasonable attorneys' fees and expert fees, prosecutions, payment of any and all fines or penalties, and the cost of abatement or remediation arising out of or relating to a hazardous condition created by Contractor, Subcontractor, Supplier, or anyone else for whom Contractor is responsible.

E. Contractor shall be responsible for coordinating any exchange of material safety data sheets or other hazard communication information required to be made available to or exchanged between or among employers of the site in accordance with all applicable Laws.

4.06 Borrow and Waste Sites

A. Unless borrow or waste sites are designated on the Plans or specified in the Supplementary Conditions, the Contractor shall secure and operate such sites at their own expense. These borrow and waste sites shall be operated in such a manner as to meet safety and health requirements all Laws and Regulations.

ARTICLE 5 - INSURANCE AND BONDS

5.01 Contractor's Liability Insurance

A. Contractor shall secure from the date of the Agreement and maintain for such periods of time as set forth below, insurance of such types and in such amounts specified in Sections 5.02 through 5.05, inclusive. The form of such insurance together with carriers thereof, shall satisfy the requirements set forth below in Sections 5.02 through 5.06, inclusive.

5.02 Commercial General Liability

A. Contractor shall secure and maintain from the date of the Agreement and for a period of at least two (2) years from the date of Final Completion of the entire Work commercial general liability insurance ("CGL") with a combined single limit of not less than Two Million Dollars (\$2,000,000) per occurrence. If such CGL insurance contains a general aggregate limit, it shall separately apply to this Project. Such CGL insurance shall be on an occurrence basis.

B. CGL insurance shall be written on a comprehensive form and shall cover claims and liability in connection with or resulting from the Contractor's operations and activities under the Contract, for personal injuries, occupational sickness, disease, death or damage to property of others, including loss of use resulting therefrom, arising out of any operations or activities of the Contractor, its agents, or any Subcontractors of any tier or by anyone directly or indirectly employed by either of them.

C. CGL insurance shall include premises, operations, independent contractors, products-completed operations, personal injury and advertising injury and liability assumed under an insured contract (including the tort liability of another assumed in a business contract) coverages. In particular, and not by way of any limitation, the CGL insurance shall cover the Contractor's deference and indemnity obligations contained in the Contract Documents.

D. There shall be no endorsement or modification of the CGL policy limiting the scope of coverage for liability arising from blasting, explosion, collapse, or underground property damage.

E. "The City of Grain Valley, Missouri" shall be endorsed as an "additional insured" under the CGL policy. In lieu of naming the City of Grain Valley, Missouri as an additional insured, under the CGL policy, Contractor may satisfy such requirement by purchasing and maintaining an Owner's and Contractor's Protective Liability policy on behalf of Owner, as named insured with limits as provided for in Paragraph 5.02 A. The CGL policy shall also contain a "Separation of Insureds" provision. If Contractor's CGL policy does not contain a "Separation of Insureds" provision, Contractor's CGL policy shall be endorsed to provide cross-liability coverage.

F. Contractor waives all rights against Owner and its agents, officers, representatives and employees for recovery of damages to the extent those damages are covered by the CGL policy required hereunder.

5.03 Automobile Liability

A. Contractor shall secure and maintain from the date of the Contract for Construction and for a period of at least two (2) years from the date of Final Completion of the entire Work, insurance, to be on comprehensive form, which shall protect Contractor against any and all claims for all injuries and all damage to property arising from the use of automobiles, trucks and motorized vehicles, in connection with the performance of Work under this Contract, and shall cover the operation on or off the site of the Work of all motor vehicles licensed for highway use whether they are owned, non-owned or hired. Such insurance shall include contractual liability coverage and shall provide coverage on the basis of the date of any accident. The liability limits under such policy shall not be less than Two Million Dollars (\$2,000,000) combined single limit for bodily injury and property damage per accident. "The City of Grain Valley, Missouri" shall be endorsed as an "additional insured" under the policy required by this Paragraph 5.03 A.

B. Contractor waives all rights against Owner and its agents, officers, directors and employees for recovery of damages to the extent such damages are covered by the automobile liability insurance required hereunder.

5.04 Workers' Compensation Insurance

A. Contractor shall purchase and maintain workers' compensation insurance and employers' liability insurance which shall protect Contractor from claims for injury, sickness, disease or death of Contractor's employees or statutory employees. The insurance policies required hereunder shall include an "all states" or "other states" endorsement. In case any Work is sublet, Contractor shall require any Subcontractor of any tier to provide the insurance coverages required under this Section 5.04.

B. Contractor's workers' compensation insurance coverage shall be in compliance with all applicable Laws, including the statutes of the State of Missouri. Contractor's employers' liability coverage limits shall not be less than \$500,000 each accident for bodily injury by accident or \$500,000 each employee for bodily injury by disease.

C. Contractor waives all rights against Owner and its agents, officers and directors and employees for recovery of damages to the extent these damages are covered by the workers' compensation and/or employers' liability insurance required hereunder.

5.05 Miscellaneous Liability Insurance

A. If required by the Supplementary Conditions, Contractor shall also secure and maintain Owner's and Contractor's Protective Liability insurance on behalf of Owner, as named insured, with a minimum limit of coverage as set forth in the Supplementary Conditions.

B. If the Work is to be performed in or adjacent to a railroad right-of-way or if required by the Supplementary Conditions, Contractor shall secure on behalf of such applicable railroad company, as named insured, railroad protective liability insurance with minimum liability limits set forth in the Supplementary Conditions. Such insurance shall protect and defend the railroad company against claims as a result of the operations of Contractor. This insurance shall be acceptable to the railroad and shall be maintained throughout the period when Contractor is working on or adjacent to property the railroad company has an interest. Contractor shall not enter upon the property the railroad company has an interest until such insurance is in effect.

C. Contractor shall also provide any type of insurance not described above which Contractor requires for its own protection or on account of any applicable Laws.

5.06 General Requirements For Liability Insurance Coverages

A. All insurance coverages required herein shall be provided by insurance companies that are duly licensed to conduct business in the State of Missouri as an admitted carrier. The form and content of all insurance coverages provided by Contractor are subject to the approval of Owner. All required coverages shall be obtained and

paid for by Contractor. Any acceptance of the form, content or insurance company by Owner shall not relieve the Contractor from the obligation to provide the coverages required herein.

B. All insurance coverage procured by the Contractor shall be provided by insurance companies having policyholder ratings no lower than "A" and financial ratings not lower than "XII" in the Best's Insurance Guide, latest edition in effect as of the date of the Agreement, and subsequently in effect at the time of renewal of any policies required by the Contract Documents. Insurance coverages required hereunder shall not be subject to a deductible amount on a per-claim basis of more than \$10,000.00 and shall not be subject to a per-occurrence deductible of more than \$25,000.00. Insurance procured by Contractor covering the additional insureds shall be primary insurance and any insurance maintained by Owner shall be excess insurance.

C. All insurance required hereunder shall provide that the insurer's cost of providing the insureds a defense and appeal, including attorneys' fees, shall be supplementary and shall not be included as part of the policy limits but shall remain the insurer's separate responsibility. Contractor shall cause its insurance carriers to waive all rights of subrogation against the Owner and its officers, employees and agents.

D. The Contractor shall furnish the Owner with certificates, policies or binders which indicate the Contractor and Owner are covered by the required insurance showing the type, amount, class of operations covered, effective dates and date of expiration of policies. Such certificates, policies or binders shall be submitted to Owner within ten (10) days from the date Contractor receives notice of the award of the Contract. All certificates, policies and binders shall be executed by a duly authorized agent of each of the applicable insurance carriers and shall contain the statement that: "The insurance covered by this certificate will not be canceled or altered except after thirty (30) days' written notice has been received by Owner." All certificates, policies and binders shall be in a form acceptable to the Owner. Contractor shall provide certified copies of all insurance policies required above within ten (10) days of Owner's written request for said copies.

E. With respect to all insurance coverages required to remain in force and affect after final payment, Contractor shall provide Owner additional certificates, policies and binders evidencing continuation of such insurance coverages along with Contractor's application for final payment and shall provide certificates, policies and binders thereafter as requested by Owner.

F. The maintenance in full current force and effect of such forms and amounts of insurance and bonds required by the Contract Documents shall be a condition precedent to Contractor's exercise or enforcement of any rights under the Contract Documents.

G. Failure of Owner to demand certificates, policies and binders evidencing insurance coverages required by the Contract Documents, acceptance by Owner of such certificates, policies and binders or failure of Owner to identify a deficiency from evidence that is provided by Contractor shall not be construed as a waiver of Contractor's obligations to maintain the insurance required by the Contract Documents.

H. The Owner shall have the right to terminate the Contract if Contractor fails to maintain the insurance required by the Contract Documents.

I. If Contractor fails to maintain the insurance required by the Contract Document, Owner shall have the right, but not the obligation, to purchase said insurance at Contractor's expense. If Owner is damaged by Contractor's failure to maintain the insurance required by the Contract Documents, Contractor shall bear all reasonable costs properly attributable to such failure.

J. By requiring the insurance set forth herein and in the Contract Documents, Owner does not represent or warrant that coverage and limits will necessarily be adequate to protect Contractor, and such coverages and limits shall not be deemed as a limitation on Contractor's liability under the indemnities granted to Owner in the Contract Documents.

K. If Contractor's liability policies do not contain a standard separation of insureds provision, such policies shall be endorsed to provide cross-liability coverage.

L. If a part of the Work hereunder is to be sublet, the Contractor shall: (1) cover any and all Subcontractors in its insurance policies; (2) require each Subcontractor to secure insurance which will protect said Subcontractor and supplier against all applicable hazards or risks of loss designated in accordance with Article 5 hereunder; and (3) require each Subcontractor or supplier to assist in every manner possible in the reporting and investigation of any accident, and upon request, to cooperate with any insurance carrier in the handling of any claim by securing and giving evidence and obtaining the attendance of witnesses as required by any claim or suit.

M. It is understood and agreed that the insurance coverages required by the provisions of this Article 5 are required in the public interest and that the Owner does not assume any liability for acts of Contractor or Subcontractors of any tier or their employees in the performance of the Contract or Work.

5.07 Property Insurance

A. The Contractor shall purchase and maintain, in a company or companies lawfully authorized to do business in the State of Missouri, as an admitted carrier, builder's risk insurance on the entire Work. Such insurance shall be written on a completed value form and in the amount of the initial Contract Price as well as subsequent modifications thereto for the entire Work. The insurance shall apply on a replacement cost basis.

B. The insurance as required in Paragraph 5.07 shall name as insureds the Owner, Contractor and all Subcontractors of any tier. The insurance policy shall contain a provision that the insurance will not be canceled, allowed to expire or materially changed until at least thirty (30) days prior written notice has been given to Owner.

C. The insurance as required in Paragraph 5.07 shall cover the entire Work, including reasonable compensation for Professional's services and expenses made necessary by an insured loss. Insured property shall include portions of the Work located away from the site but intended for use at the site, and shall also cover portions of the Work in transit, including ocean transit. The policy shall include as insured property scaffolding, falsework, and temporary buildings located at the site. The policy shall cover the cost of removing debris, including demolition as may be made legally necessary by the operation of any law, ordinance or regulation.

D. The insurance required by Paragraph 5.07 shall be on an all risk form and shall be written to cover all risks of physical loss or damage to the insured party and shall insure at least against the perils of fire and extended coverage, theft, vandalism, malicious mischief, collapse, lightning, earthquake, flood, frost, water damage, windstorm and freezing.

E. If there are any deductibles applicable to the insurance required by Paragraph 5.07, Contractor shall pay any part of any loss not covered because of the operation of such deductibles.

F. The insurance as required in Paragraph 5.07 shall be maintained in effect until the earliest of the following dates:

1. the date which all persons and organization who are insureds under the policy agree in writing that it shall be terminated;
2. the date on which final payment of this Contract has been made by Owner to Contractor; or
3. the date on which the insurable interests in the property of all insureds other than the Owner have ceased.

G. Contractor shall purchase and maintain boiler and machinery insurance required by the Supplementary Conditions, which shall specifically cover such insured objects during installation until final acceptance by the Owner. This insurance shall name as insureds Owner, Contractor and Subcontractors of any tier in such Work.

H. The Owner and Contractor waive all rights against (1) each other and any of their subcontractors of any tier, suppliers, agents and employees, each of the other, (2) the Professional and Professional's consultants, and (3) separate contractors described in Article 6, if any, and any of their subcontractors of any tier, suppliers, agents and employees, for damages caused by fire or other perils to the extent covered by property insurance obtained pursuant to this Section 5.07 or other insurance applicable to the Work, except such rights as they have to proceeds of such insurance. The Owner or Contractor, as appropriate, shall require of the Professional, Professional's consultants, separate contractors described in Article 7, if any, and the Subcontractors of any tier, Suppliers, agents and employees of any of them, by appropriate agreements, written where legally required for validity, similar waivers each in favor of other parties enumerated herein. The policies shall provide such waivers of subrogation by endorsement or otherwise. A waiver of subrogation shall be effective as to a person or entity even though that person or entity would otherwise have a duty of indemnification, contractual or otherwise, did not pay the insurance premium directly or indirectly, was at fault or was negligent in causing the loss and whether or not the person or entity had an interest in the property damaged.

I. A loss insured under Contractor's property insurance shall be adjusted by the Owner in good faith and made payable to the Owner for the insureds, subject to requirements of the Contract Documents. The Contractor shall pay Subcontractors of any tier their just shares of insurance proceeds received by the Contractor, and by appropriate agreements, written where legally required for validity, shall require Subcontractors of any tier to make payments to their Sub-subcontractors in similar manner.

J. Partial occupancy or use shall not commence until the insurance company or companies providing property insurance have consented to such partial occupancy or use by endorsement or otherwise. The Owner and the Contractor shall take reasonable steps to obtain consent of the insurance company or companies and shall, without mutual written consent, take no action with respect to partial occupancy or use that would cause cancellation, lapse or reduction of insurance.

5.08 Bonds

A. The Contractor shall procure and furnish a Performance and Payment Bond in the form prepared by the Owner, in an amount equal to one hundred percent (100%) of the Contract Price, as well as adjustments to the Contract Price. The Performance Bond shall secure and guarantee Contractor's faithful performance of this Contract, including but not limited to Contractor's obligation to correct defects after final payment has been made as required by the Contract Documents. The Payment Bond shall secure and guarantee payment of all persons performing labor on the Project under this Contract and furnishing materials in connection with this Contract. These Bonds shall be in effect through the duration of the Contract plus the Guarantee Period as required by the Contract Documents.

B. The bonds required hereunder shall be executed by a responsible surety licensed in the State of Missouri, with a Best's rating of no less than A/XII. The Contractor shall require the attorney in fact who executes the required bonds on behalf of the surety to affix thereto a certified and current copy of this power of attorney indicating the monetary limit of such power.

C. If the surety of any bond furnished by Contractor is declared bankrupt or becomes insolvent or its right to conduct business in the State of Missouri is terminated, or it ceases to meet the requirements of this paragraph, Contractor shall within ten (10) days substitute another bond and surety, both of which must be acceptable to Owner. If Contractor fails to make such substitution, Owner may procure such required bonds on behalf of Contractor at Contractor's expense.

D. Upon the request of any person or entity appearing to be a potential beneficiary of bonds covering payment of obligations arising under the Contract, the Contractor shall promptly furnish a copy of the bonds to such person or entity.

E. The Contractor shall keep the surety informed of the progress of the Work, and, where necessary, obtain the surety's consent to or waiver of: (1) notice of changes in the Work; (2) request for reduction or release of retention; (3) request for final payment; and (4) any other material required by the surety. The Owner shall be notified by the Contractor, in writing, of all communications with the surety. The Owner may, in the Owner's sole discretion, inform surety of the progress of the Work, any defects in the Work, or any defaults of Contractor under the Contract Documents and obtain consents as necessary to protect the Owner's rights, interest, privileges and benefits under and pursuant to any bond issued in connection with the Work.

F. Contractor shall indemnify and hold harmless the Owner and any agents, employees, representative or elected official of Owner from and against any claims, expenses, losses, costs, including reasonable attorneys' fees, as a result of any failure of Contractor to procure the bonds required by this Paragraph 5.08.

ARTICLE 6 - CONTRACTOR'S RESPONSIBILITY

6.01 General

A. The Contractor shall supervise and direct the Work, using the Contractor's best skill and attention. Contractor shall supervise and direct the Work competently and efficiently, devoting such attention thereto and applying such skills and expertise as may be necessary to perform the Work in accordance with the Contract Documents. Contractor shall be solely responsible for the means, methods, techniques, sequences and procedures of construction. Contractor shall be responsible to see that the finished Work strictly complies with the Contract Documents.

6.02 Supervision

A. The Contractor shall be solely responsible for and have control over construction means, methods, techniques, sequences, and procedures and for coordinating all portions of the Work under the Contract. The Contractor shall supply sufficient and competent supervision and personnel, and sufficient material, plant, and equipment to prosecute the Work with diligence to insure completion thereof within the time specified in the Contract Documents, and shall pay when due any laborer, Subcontractor of any tier, or supplier. Contractor shall keep on the Work at all times during its progress, a competent resident superintendent, who shall not be replaced without written notice to Owner and Professional except under extraordinary circumstances. The superintendent will be Contractor's representative at the Site and shall have authority to act on behalf of Contractor. All communications given to the superintendent shall be as binding as if given to Contractor.

6.03 Labor and Construction Procedures

A. Contractor shall provide competent, suitably qualified personnel to survey and lay out the Work and perform construction as required by the Contract Documents. Contractor shall at all times maintain good discipline and order at the site. Except in connection with the safety or protection of persons or the Work or property at the site or adjacent thereto, and except as otherwise indicated in the Contract Documents, all Work at the site shall be performed during regular working hours, and Contractor will not permit overtime work or the performance of the Work

on Saturday, Sunday or any legal holiday without Owner's written consent given after prior written notice to Professional.

B. The Contractor shall only employ labor on the Project or in connection with the Work capable of working harmoniously with all trades, crafts and any other individuals associated with the Project. The Contractor shall take all measures to minimize the likelihood of any strike, work stoppage or other labor disturbance. If the Work is to be performed by trade unions, the Contractor shall make all necessary arrangements to reconcile, without delay, damage or cost to the Owner and without recourse to the Professional or Owner, any conflict between the Contract Documents and any agreements or regulations of any kind at any time in force among members or councils which regulate or distinguish what activities shall not be included in the Work of any particular trade. In case the progress of the Work is affected by any undue delay in furnishing or installing any items or materials or equipment required under the Contract Document because of such conflict involving any such labor agreement or regulation, the Owner may require that other material or equipment of equal kind and quality be provided pursuant to a Change Order or Work Change Directive. Notwithstanding any other provision contained herein and superseding any contrary term expressed herein or in any of the Contract Documents, Contractor agrees that in the event of any strike, picket, sympathy strike, work stoppage, or other form of labor dispute (collectively referred to as "Disruption") at the Project site, whether that Disruption is in connection with Contractor, a Subcontractor of any tier, the Owner or any other contractor, subcontractor or supplier on this Project site, Contractor will continue to perform the Work required herein without interruption or delay. In the event Contractor fails to continue the performance of the Work included herein, without interruption or delay, because of such Disruption or other form of labor dispute, the Owner may terminate the services of Contractor after giving forty-eight (48) hours written notice of an intent to do so, or the Owner may invoke any of the rights set forth in the Contract Documents. Contractor expressly waives the right to any extension of time for any delay that may occur as the result of any Disruption, strike, picket, sympathy strike, work stoppage or other form of labor dispute at the Project site. Whenever Contractor has knowledge that any actual or potential Disruption or labor dispute is delaying or threatens to delay the timely performance of the Project, Contractor shall immediately notify Owner in writing.

C. The Contractor shall establish and maintain a permanent bench-mark to which access may be had during progress of the Work, and Contractor shall establish all lines and levels, and shall be responsible for the correctness of such. Contractor shall protect the established benchmarks and horizontal and vertical control points. Benchmarks and control points destroyed or that require relocation because of necessary construction activities shall be immediately reported to Professional. Contractor shall be fully responsible for all layout work for the proper location of Work in strict accordance with the Contract Documents. The Contractor shall establish and maintain alignment and grades, including the setting of all stakes, ranges, grid lines and other appurtenance facilities. Contractor shall carefully protect and maintain such stakes and keep the same uncovered for examination during the progress of the Work. Before starting construction on the site, the Contractor shall provide written assurances certifying that the monuments or markers which delineate the site boundaries are placed in the correct position and that the proposed new construction and site development work, as staked-out by the Contractor, are wholly within the limits of the Owner's ownership, leasehold or right-of-way. Contractor shall be responsible for the accurate replacement of any boundary markers which are disturbed, removed or destroyed during the performance of the Work.

D. The Contractor shall be responsible for the layout of the Work in the proper location and for any damage which may occur to the Work or the work of separate contractors, because of errors or inaccuracies in the layout of the Work.

E. The Contractor shall be responsible for the shoring required to protect its work or adjacent property and shall pay for any damage caused by failure to shore or by improper shoring or by failure to give proper notice. Shoring shall be removed only after completion of permanent supports.

F. During the performance of the Work, the Contractor shall be responsible for providing and maintaining warning signs, lights, signal devices, barricades, guard rails, fences, and other devices appropriately located on site which shall give proper and understandable warning to all persons of danger of entry onto land, structure, or equipment.

G. The Contractor shall be responsible for care of the Work and must protect same from damage or defacement until acceptance by the Owner. All damaged or defaced Work shall be repaired or replaced to the Owner's satisfaction, without cost to the Owner.

H. When requested by the Contractor, at no extra charge, shall provide scaffolds or ladders in place as may be required by the Professional or the Owner for examination of Work in progress or completed.

I. The Contractor shall coordinate all Work so there shall be no prolonged interruption of existing utilities, systems and equipment of Owner. Any existing plumbing, heating, ventilating, air conditioning, or electrical disconnection necessary, which affect portions of construction or building of the Project or any other building, must be

scheduled with the Owner and Professional to avoid any disruption of operation within the building under construction or other buildings or utilities. In no case shall utilities be left disconnected at the end of a work day or over a weekend. Any interruption of utilities, either intentionally or accidentally, shall not relieve the Contractor from repairing and restoring the utility to normal service. Repairs and restoration shall be made before the workers responsible for the repair and restoration leave the job.

J. The Contractor shall pump, bail, or otherwise keep any general excavations free of water. The Contractor shall keep all areas free of water before, during and after concrete placement.

K. The Contractor shall ensure that the Work is at all times performed in a manner that affords reasonable access, both vehicular and pedestrian, to the site of the Work and all adjacent areas. The Work shall be performed, to the fullest extent reasonably possible, in such a manner that public areas adjacent to the site of the Work shall be free from all debris, building materials and equipment likely to cause hazardous conditions. Without limitation of any other provision of the Contract Documents, Contractor shall not interfere with the occupancy or beneficial use of (1) any areas and buildings adjacent to the site of the Work or (2) the Work in the event of partial occupancy. Contractor shall assume full responsibility for any damage to the property comprising the Project or to the owner or occupant of any adjacent land or areas resulting from the performance of the Work.

L. Contractor shall, and in accordance with any regulations or site rules presented by the Owner use only designated site entrances and roadways or use temporary entrances and roadways constructed by Contractor.

M. The Contractor shall not permit any workers to use any existing facilities at the Project site, including, without limitation, lavatories, toilets, entrances and parking areas other than those designated by Owner. The Contractor, Subcontractors of any tier, suppliers and employees shall comply with instructions or regulations of the Owner and Professional governing access to, operation of, and conduct while in or on the premises and shall perform all Work required under the Contract Documents in such a manner as not to unreasonably interrupt or interfere with the conduct of Owner's operations. Any request for Work, a suspension of Work or any other request or directive received by the Contractor from occupants of existing buildings shall be referred to the Professional for determination.

N. The Contractor shall take field measurements and verify field conditions and shall carefully compare such field measurements and conditions and other information known to the Contractor with the Contract Documents before commencing activities. Errors, inconsistencies or omissions discovered shall be reported in writing to the Professional and Owner within twenty-four (24) hours. During the progress of Work, Contractor shall verify all field measurements prior to fabrication of building components or equipment, and proceed with the fabrication to meet field conditions. Contractor shall consult all Contract Documents to determine the exact location of all Work and verify spatial relationships of all Work. Any question concerning said location or spatial relationships shall be submitted to the Professional. Specific locations for equipment, pipelines, ductwork and other such items of Work, where not dimensioned on plans, shall be determined in consultation with Professional. Contractor shall be responsible for the proper fitting of the Work in place. The exactness of grades, elevations, dimensions, or locations given on any Drawings issued by the Professional, or the work installed by separate contractors, is not guaranteed by the Professional or the Owner. The Contractor shall, therefore, satisfy itself as to the accuracy of all grades, elevations, dimensions and locations. In all cases of interconnection of its Work with existing or other work, Contractor shall verify at the site all dimensions relating to such existing or other work. Any errors due to the Contractor's failure to so verify all such grades, elevations, locations or dimensions shall be promptly rectified by the Contractor without any additional cost to the Owner.

O. The Contractor shall be responsible for inspection of portions of the Work already performed under this Contract to determine that such portions are in proper condition to receive subsequent Work.

P. Before ordering any materials or doing any Work, the Contractor and each Subcontractor shall verify measurements at the Project site and shall be responsible for the correctness of such measurements. No extra charge or compensation will be allowed on account of differences between actual dimensions and the dimensions indicated on the Drawings. Any difference which may be found shall be submitted to the Professional for resolution before proceeding with the Work. If a minor change in the Work is found to be necessary due to actual field conditions, the Contractor shall submit detailed drawings of such departure for the approval by the Professional before making the change.

6.04 Materials and Equipment

A. Contractor shall furnish and assume full responsibility for all materials, equipment, labor, transportation, construction equipment and machinery, tools, appliances, fuel, power, light, heat, telephone, water, sanitary facilities, temporary facilities and all other facilities and incidentals necessary for the furnishing, performance, testing, start-up and completion of the Work.

B. Unless otherwise specifically noted, the Contractor shall provide and pay for supervision, labor, materials, equipment, tools, construction equipment and machinery, water, heat, utilities, transportation, and other

facilities and services necessary for the proper execution and completion of the Work, whether temporary or permanent and whether or not incorporated in the Work. Contractor shall arrange for and pay all fees and charges for installation of motors and other devices and connection to existing outside services and utilities necessary for the Work. Contractor shall pay for bills for utilities for the Contractor's use and consumption of utilities until the date of Substantial Completion. Contractor, unless otherwise provided for in the Special Conditions, shall provide an office and maintain the office for use by Contractor, Professional and Owner. The office shall be removed when directed by Owner. Contractor shall provide heat, air conditioning, ventilation, other environmental controls and shall take all actions necessary to protect all Work, materials and equipment against injury, damage or loss from theft, weather, vandalism, wetness, temperature and humidity conditions, dust and other adverse environmental conditions.

6.05 Quality of Materials and Equipment

A. All materials and equipment shall be of good quality and new, except as otherwise provided in the Contract Documents. If required by Professional, Contractor shall furnish satisfactory evidence (including reports of required tests) as to the kind and quality of materials and equipment. All materials and equipment shall be applied, installed, connected, erected, used, cleaned and conditioned in accordance with the instructions of the applicable Supplier except as otherwise provided in the Contract Documents. No provision of any such instructions will be effective to assign to Professional, Owner or any of Professional's or Owner's consultants, agents or employees, any duty or authority to supervise or direct the furnishing or performance of the Work.

B. Materials and workmanship shall be subject to inspection, examination, and test by the Professional at any and all times during manufacture, installation and construction of any of them, at places where such manufacture, installation or construction is performed.

6.06 Schedule

A. Contractor shall submit to Professional for acceptance adjustments in the progress schedule to reflect the impact thereon of new developments. These will conform generally to the progress schedule then in effect and additionally will comply with any provisions of the General Requirements applicable thereto. The submission or acceptance of such schedules shall not change or modify the Contract Times. Adjustments in the progress schedule that will change the Contract Times or Milestones shall be submitted in accordance with Article 12. An adjustment in the Contract Times or Milestones may only be made by Change Order in accordance with Article 12 regardless of the submission of a progress schedule or acceptance of such schedule.

B. The Contractor shall monitor the progress of the Work for conformance with the requirements of the most recently approved schedule and shall promptly advise the Owner of any delays or potential delays. The accepted construction schedule shall be updated to reflect actual conditions. Contractor shall submit written progress reports and updated schedules to Professional and Owner with each Application for Payment showing actual progress of the Work compared with the scheduled and planned progress. In the event any schedule or progress report indicates any delays, the Contractor shall propose an affirmative plan to correct the delay, including overtime and/or additional labor and equipment and/or expediting delivery of materials, if necessary. In no event shall any progress report or construction schedule constitute an adjustment in the Contract Times, any Milestone Date or the Contract Price unless any such adjustment is agreed to by the Owner and authorized pursuant to Change Order.

C. In the event the Owner or Professional determines that the performance of the Work, as of a Milestone Date, has not progressed or reached the level of completion required by the Contract Documents, the Owner shall have the right to order the Contractor to take corrective measures necessary to expedite the progress of construction, including, without limitation, (1) working additional shifts or overtime, (2) supplying additional manpower, equipment, facilities, (3) expediting delivery of materials, and (4) other similar measures (hereinafter referred to collectively as Extraordinary Measures). Such Extraordinary Measures shall continue until the progress of the Work complies with the stage of completion required by the Contract Documents. The Owner's right to require Extraordinary Measures is solely for the purpose of ensuring the Contractor's compliance with the construction schedule. The Contractor shall not be entitled to an adjustment in the Contract Price in connection with Extraordinary Measures required by the Owner under or pursuant to this Paragraph 6.06 C. The Owner may exercise the rights furnished the Owner under or pursuant to this Paragraph 6.06 C. as frequently as the Owner deems necessary to ensure that the Contractor's performance of the Work will comply with any Milestone Date or completion date set forth in the Contract Documents.

6.07 "Or-Equal" Items

A. Whenever materials or equipment are specified or described in the Contract Documents by using the name of a proprietary item or the name of a particular Supplier the naming of the item is intended to establish the type, function and quality required. Unless the name is followed by words indicating that no substitution is permitted, materials or equipment of other Suppliers may be accepted by Professional if it is proven as set forth in this Section 6.07 that the material or equipment proposed is equivalent or equal to that named.

B. The standard products of manufacturers other than those specified will be accepted when, prior to the ordering or use thereof, it is proven to the satisfaction of the Professional that such products are equal in design, appearance, spare parts availability, strength, durability, usefulness, serviceability, operation cost, maintenance cost, and convenience for the purpose intended. Any general listings of approved manufacturers in any Contract Document shall be for informational purposes only and it shall be the Contractor's sole responsibility to ensure that any proposed "or equal" complies with the requirements of the Contract Documents.

C. In the event that Contractor desires to propose an "or equal" of any article, appliance, device or material, Contractor shall submit a written list of all proposed or equals that Contractor proposes to provide to the Professional and within ten (10) days from the execution of the Agreement. Within ten (10) days from the execution of the Agreement, the Contractor shall submit to Professional and a written and full description of the proposed "or equal" including all supporting data, including technical information, catalog cuts, warranties, test results, installation instructions, operating procedures, and similar information demonstrating that the proposed "or equal" strictly complies with the Contract Documents. The Professional shall take appropriate action with respect to the submission of a proposed "or equal" item. If Contractor fails to submit proposed "or equals" as set forth herein, it shall waive any right to supply such items. The Contract Price and Contract Times shall not be adjusted as a result of any failure by Contractor to submit proposed "or equals" as provided for herein. All documents submitted in connection with preparing an "or equal" shall be clearly and obviously marked as a proposed "or equal" submission.

D. No "or equal" items shall be installed or utilized until Professional's review is complete and approved in writing. No approvals or action taken by the Professional or shall relieve Contractor from its obligation to ensure that an "or equal" article, appliance, device or material strictly complies with the requirements of the Contract Documents. Contractor shall not propose "or equal" items in connection with Shop Drawings or other Submittals, and Contractor acknowledges and agrees that no approvals or action taken by the Professional or with respect to Shop Drawings or other Submittals shall constitute approval of any "or equal" item or relieve Contractor from its sole and exclusive responsibility. Any changes required in the details and dimensions indicated in the Contract Documents for the incorporation or installation of any "or equal" item supplied by Contractor shall be properly made and approved by the Professional at the expense of the Contractor. No "or equal" items will be permitted for components of or extensions to existing systems when, in the opinion of the Professional, the named manufacturer must be provided in order to insure compatibility with the existing systems, including, but not limited to, mechanical systems, electrical systems, fire alarms, smoke detectors, etc. No action will be taken by the Professional with respect to proposed "or equal" items prior to receipt of bids, unless otherwise noted in the Supplementary Conditions.

6.08 Substitutions

A. If, after execution of the Contract or prior to submittal of applicable Shop Drawings, the Contractor desires to submit an alternate product or method in lieu of what has been specified or shown in the Contract Documents, which is not an "or equal" as set forth in Section 6.07, the Contractor may do so in writing and setting forth the following:

1. Full explanation of the proposed substitution and submittal of all supporting data including technical information, catalog cuts, warranties, test results, installation instructions, operating procedures, and other like information necessary for a complete evaluation of the substitution.
2. Reasons the substitution is advantageous and necessary, including the benefits to the Owner and the Work in the event the substitution is acceptable.
3. The adjustment, if any, in the Contract Price, in the event the substitution is acceptable.
4. The adjustment, if any, in the time of completion of the Contract and the construction schedule in the event the substitution is acceptable.
5. An affidavit stating that (a) the proposed substitution conforms to and meets all of the Contract Documents, except as specifically disclosed and set forth in the affidavit and (b) the Contractor accepts the warranty and correction obligations in connection with the proposed substitution as if originally specified by the Professional. Proposals for substitutions shall be submitted to the Professional and in sufficient time to allow the Professional and no less than ten (10) working days for review. No substitution will be considered or allowed without the Contractor's submittal of complete substantiating data and information as stated herein.

B. Substitutions and alternates may be rejected without explanation in Owner's sole discretion and will be considered only under one or more of the following conditions:

1. Required for compliance with interpretation of code requirements or insurance regulations then existing;
2. Unavailability of specified products, through no fault of the Contractor;

3. Material delivered fails to comply with the Contract Documents;
4. Subsequent information discloses inability of specified products to perform properly or to fit in designated space;
5. Manufacturer/fabricator refuses to certify or guarantee performance of specified product as required; or
6. When in the judgment of the Owner or the Professional, a substitution would be substantially to the Owner's best interests, in terms of cost, time, or other considerations.

C. Professional and Owner shall be allowed a reasonable time to evaluate each substitute proposed. No substitute will be ordered, included or utilized until Professional's review is complete and approved, which will be evidenced by a Change Order. Owner may require Contractor to furnish at Contractor's expense a special performance guarantee or other guaranty with respect to any substitution. Whether or not any proposed substitution is accepted by the Owner or the Professional, the Contractor shall reimburse the Owner for any fees charged by the Professional or other consultants for evaluating each proposed substitute.

6.09 Concerning Subcontractors, Suppliers and Others

A. Contractor shall not employ any Subcontractor, Supplier or other person or organization whether initially or as a substitute, against whom Owner or Professional may have reasonable objection. Contractor shall not be required to employ any Subcontractor, Supplier or other person or organization to furnish or perform any of the Work against whom Contractor has reasonable objection.

B. If the Supplementary Conditions require the identity of certain Subcontractors, Suppliers or other persons or organizations (including those who are to furnish the principal items of materials and equipment) to be submitted to Owner in advance of the specified date prior to the Effective Date of the Agreement for acceptance by Owner and Professional and if Contractor has submitted a list thereof in accordance with the Supplementary Conditions, Owner's or Professional's acceptance (either in writing or by failing to make written objection thereto by the date indicated for acceptance or objection in the bidding documents or the Contract Documents) of any such Subcontractor, Supplier or other person or organization so identified may be revoked on the basis of reasonable objection after due investigation, in which case Contractor shall submit an acceptable substitute. The Contract Price shall be increased by the difference between the subcontract amount proposed by the person or entity recommended by the Contractor and the subcontract amount proposed by the person or entity to whom the Owner has no objection. However, no increase in the Contract Price shall be allowed unless the Contractor has acted promptly and responsively in complying with the provisions of Paragraph 6.09 B and the person or entity to which Owner has an objection is capable of performing the Work. No acceptance by Owner or Professional of any such Subcontractor, Supplier or other person or organization shall constitute a waiver of any right of Owner or Professional to reject defective Work.

C. Each subcontract agreement for a portion of the Work is assigned by the Contractor to the Owner provided that:

1. assignment is effective only after termination of the Contract by the Owner for cause pursuant to Paragraph 15.01 and only for those subcontract agreements which the Owner accepts by notifying the Subcontractor in writing; and
2. assignment is subject to the prior rights of the surety, if any, obligated under bond relating to the Contract.

Each subcontract shall specifically provide that the Owner shall only be responsible to the Subcontractor for those obligations of the Contractor that accrue subsequent to the Owner's exercise of any rights under this conditional assignment.

D. Contractor shall be fully responsible to Owner and Professional for all acts and omissions of the Subcontractors, Suppliers and other persons and organizations performing or furnishing any of the Work under a direct or indirect contract with Contractor just as Contractor is responsible for Contractor's own acts and omissions. Nothing in the Contract Documents shall create any contractual relationship between Owner or Professional and any such Subcontractor, Supplier or other person or organization, nor shall it create any obligation on the part of Owner or Professional to pay or to see to the payment of any moneys due any such Subcontractor, Supplier or other person or organization except as may otherwise be required by Laws and Regulations.

E. The divisions and sections of the Specifications and the identifications of any Drawings shall not control the Contractor in dividing the Work among Subcontractors or Suppliers or delineating the Work to be performed by any specific trade.

F. All Work performed for Contractor by a Subcontractor will be pursuant to an appropriate agreement between Contractor and the Subcontractor which specifically binds the Subcontractor to the applicable terms and

conditions of the Contract Documents for the benefit of Owner and Professional and contains waiver provisions as required by Section 5.07. Contractor shall pay each Subcontractor a just share of any insurance moneys received by Contractor on account of losses under policies issued pursuant Section 5.07.

G. Contractor shall perform with its own forces and organization Work amounting to not less than thirty percent (30%) (or a greater percentage if required by the Supplementary Conditions) of the original Contract Price.

6.10 Patent Fees and Royalties

A. Contractor shall pay all license fees and royalties and assume all costs incident to the use in the performance of the Work or the incorporation in the Work of any invention, design, process, product or device which is the subject of patent rights or copyrights held by others. If a particular invention, design, process, product or device is specified in the Contract Documents for use in the performance of the Work and if to the actual knowledge of Owner or Professional its use is subject to patent right or copyrights calling for the payment of any license fee or royalty to others, the existence of such rights shall be disclosed by Owner in the Contract Documents. Contractor shall defend, indemnify and hold harmless Owner and Professional and anyone directly or indirectly employed by either of them from and against all claims, damages, losses and expenses (including attorney's fees and court and arbitration costs) arising out of any infringement of patent rights or copyrights incident to the use in the performance of the Work of any invention, design, process, product or device not specified in the Contract Documents, and shall defend all such claims in connection with any alleged infringement of such rights.

6.11 Permits and Fees

A. Contractor shall pay all governmental charges and inspection fees necessary for the prosecution of the work, which are applicable at the time of opening of Bids, or if there are no Bids on the Effective Date of the Agreement, Contractor shall pay all governmental charges and inspection fees necessary for the completion of the Work, which are applicable at the time of opening of Bids. Contractor shall pay all charges or assessments of utility owners for connections of utilities to the Work.

B. Contractor shall procure and obtain all bonds required of the Owner or the Contractor by the municipality in which the Project is located or any other public or private body with jurisdiction over the Project. In connection with such bonds, the Contractor shall prepare all applications, supply all necessary backup material, and furnish the surety with any required personal undertakings. Contractor shall also obtain and pay all charges for all approvals for street closings, parking meter removal, and other similar matters as may be necessary or appropriate from time to time for the performance of the Work.

6.12 Laws and Regulations

A. Contractor shall give all notices and comply with all Laws and Regulations applicable to furnishing and performance of the Work. Except where otherwise expressly required by applicable Laws and Regulations, neither Owner nor Professional shall be responsible for monitoring Contractor's compliance with any Laws or Regulations.

B. If Contractor observes that the Specifications or Drawings are at variance with any Laws or Regulations, Contractor shall give Professional prompt written notice thereof. If Contractor performs any Work knowing or having reason to know that it is contrary to such Laws or Regulations, and without such notice to Professional, Contractor shall bear all costs arising therefrom; however, it shall not be Contractor's primary responsibility to make certain that the Specifications and Drawings are in accordance with such Laws and Regulations.

6.13 Prevailing Wage Rates

A. This Contract shall be based upon payment by the Contractor and his Subcontractors of wage rates not less than the prevailing hourly wage rate for each craft or classification of workman engaged on the Work as determined by the Labor and Industrial Relations Commission of Missouri on behalf of the Department of Labor and Industrial Relations. The Contractor shall comply with all requirements of the prevailing wage law of Missouri, RSMo. §§ 290.210 to 290.340, including the latest amendments thereto. The Contractor and each Subcontractor shall keep an accurate record showing the names, occupations, and crafts of all workmen employed, together with the number of hours worked by each workman and the actual wages paid to each workman. At all reasonable hours, such records shall be open to inspection by the representatives of the Labor and Industrial Relations Commission of Missouri and Owner. The payroll records shall not be destroyed or removed from the state for at least two (2) years after completion of the Work. Throughout the life of this Contract, a copy of the wage determination and the rules promulgated by the Labor and Industrial Relations Commission of Missouri shall be displayed in at least four (4) conspicuous places on the Project under a heading of NOTICE, with the heading in letters at least one (1) inch high. Pursuant to RSMo. § 290.250, the Contractor shall forfeit to Owner as a penalty, Ten Dollars (\$10.00) for each workman employed, for each calendar day, or portion thereof, such workman is paid less than the stipulated rates for any work done under the Contract, by him or by any Subcontractor under him. After completion of the Work, and before final payment can be made under this Contract, the Contractor and each Subcontractor must file with Owner an affidavit of compliance stating that he has fully complied with the provisions and requirements of the prevailing

295893v1

wage law of Missouri. During the life of this Contract, the prevailing hourly rate of wages is subject to change by the Department of Labor and Industrial Relations or by court decision, as provided by law. Any such change shall not be the basis of any claim by the Contractor against Owner, nor will deductions be made by Owner against sums due the Contractor by reason of any such change.

B. If a federal governmental agency is providing funding for the Project and if required by Division 1 of the Specifications or the Contract Documents, the Contractor agrees to pay prevailing hourly rate of wages for regular, holiday and overtime work as determined by the Secretary of Labor in accordance with the Davis-Bacon Act as amended and supplemented. The Contractor further agrees to comply with all applicable federal laws, statutes and regulations relating to and establishing prevailing wage rates. Where Missouri and Federal prevailing wage rates are applicable, the higher of the two will be paid by the Contractor.

C. Violations of the Missouri prevailing wage statute, whether by the Contractor or its Subcontractors, result in additional costs for Owner, including, but not limited to, costs of construction delays, of additional work for City staff, of added interest expense, of legal and litigation expense, and of delays in the levying of special assessments. The Contractor shall ensure that prevailing wage rates are paid and that Work is done by the correct category of worker both on this Contract and on all subcontracts. The cost to Owner of any particular violation is difficult to establish; in the event of the failure by the Contractor or any of its Subcontractors to pay wages as provided in the Missouri prevailing wage Laws, Owner may deduct from the price specified in the Contract and may retain as liquidated damages, and not as a penalty, Thirty-Five Dollars (\$35.00) per day per individual who is paid less than the prevailing wage, to approximate the investigative costs resulting to Owner from such violations. To approximate the cost of delay, including interest expense from delay in levying special assessments and issuing special assessment tax bills, additional liquidated damages, and not as a penalty, shall be paid in the amount of One Hundred Dollars (\$100.00) per day for any delay in closing out the Contract occasioned by failure to pay the prevailing wage. Such additional sum shall be collected, whether or not the work days on the Contract could be closed out. Action under this section shall be commenced by Owner giving a written notice to the Contractor. The notice shall set out the persons who are claimed to have been underpaid, and the days they are claimed to have been underpaid. The Contractor shall have ten (10) days, or such longer time as Owner shall allow, to respond to the allegation. Based on the information in the notice, the response by the Contractor and such additional information as Owner shall determine, Owner shall render its decision, in writing, giving the amount of liquidated damages owed, including any damages for occasioning a delay in closing out the Contract. The Contractor shall not be required to pay liquidated damages for any false or malicious claims. This liquidated damage will be in addition to the liquidated damages specified in the Agreement.

6.14 Taxes

A. Contractor shall pay all sales, consumer, use and other similar taxes required to be paid by Contractor in accordance with the Laws and Regulations of the place of the Project which are applicable during the performance of the Work. However, certain purchases by the Contractor of materials incorporated in or consumed in the construction of the Project are exempt from certain sales taxes pursuant to RSMo 144.062. The Contractor shall be issued a Project Tax Exemption Certificate for this Project to obtain the benefits of RSMo 144.062.

B. The Contractor shall furnish this certificate to all Subcontractors, and any person or entity purchasing materials for the Work shall present such certificate to all material suppliers as authorization to purchase, on behalf of the Owner, all tangible personal property and materials to be incorporated into or consumed in the Project and no other project on a tax-exempt basis. Such suppliers shall provide the purchasing party invoices bearing the name of the exempt entity and the Project identification number. Nothing in this section shall be deemed to exempt from any sales or similar tax the purchase of any construction machinery, equipment or tools used in construction, repairing or remodeling facilities for the Owner. All invoices for all personal property and materials purchased under a Project Tax Exemption Certificate shall be obtained and retained by the Contractor for a period of five years and shall be subject to audit by the director of revenue.

C. Any excess resalable tangible personal property or materials which were purchased for the Project under this Project Tax Exemption Certificate but which were not incorporated into or consumed in the construction of the Project shall either be returned to the supplier for credit or the appropriate sales or use tax on such excess property or materials shall be reported on applicable tax returns and paid by such purchasing party not later than the due date of the purchasing party's Missouri sales or use tax return following the month in which it was determined that the materials were not used in the Project.

D. If it is determined that sales tax is owed by the Contractor on property and materials due to the failure of the Owner to revise the certificate expiration date to cover the applicable date of purchase, Owner shall be liable for the tax owed.

E. The Owner shall not be responsible for any tax liability due to Contractor's neglect to make timely orders, payments, etc. or Contractor's misuse of the Project Tax Exemption Certificate. Contractor represents that the Project Tax Exemption Certificate shall be used in accordance with RSMo § 144.062 and the terms of the Project Tax Exemption Certificate. Contractor shall defend and indemnify the Owner for any loss or expense, including but not limited to, reasonable attorneys' fees, arising out of Contractor's use of the Project Tax Exemption Certificate.

6.15 Use of Premises

A. Contractor shall confine construction equipment, the storage of materials and equipment and the operations of workers to the Project site, land and areas identified in and permitted by the Contract Documents and other land and areas permitted by Laws and Regulations, rights-of-way, permits and easements, and shall not unreasonably encumber the premises with construction equipment or other materials or equipment.

B. Contractor shall assume full responsibility for any damage to any such land or area, or to the owner or occupant thereof of any land or area, or to the owner or occupant thereof of any land or areas contiguous thereto, resulting from the performance of the Work. Should any such owner or occupant because of the performance of the Work make any claim against Owner or Professional, Contractor shall promptly attempt to settle with such other party by agreement or otherwise resolve the claim by arbitration or by law.

C. Contractor shall, to the fullest extent permitted by Laws and Regulations, indemnify and hold Owner and Professional harmless from and against all claims, damages, losses and expenses (including, but not limited to, fees of engineers, Professionals, attorneys and other professionals and court and arbitration's costs) arising directly, indirectly or consequentially out of any action, legal or equitable, brought by any such other party against Owner or Professional to the extent based on a claim arising out of Contractor's performance of the work.

6.16 Site Cleanup

A. During the progress of the Work, Contractor shall keep the premises free from accumulations of waste materials, rubbish and other debris resulting from the Work. At the completion of the Work Contractor shall remove all waste materials, rubbish and debris from and about the premises as well as all tools, appliances, construction equipment and machinery, and surplus materials, and shall leave the site clean and ready for occupancy by Owner. Contractor shall restore to original condition all property whether or not designated for alteration by the Contract Documents.

6.17 Loading of Structures

A. Contractor shall not load nor permit any part of any structure to be loaded in any manner that will endanger the structure, nor shall Contractor subject any part of the Work or adjacent property to stresses or pressures that will endanger it.

6.18 Record Documents

A. Contractor shall maintain in a safe place at the site one record copy of all Drawings, Specifications, Addenda, Written Amendments, Change Orders, Work Directive Changes, Field Orders and written interpretations and clarifications in good order and annotated to show all changes made during construction. These record documents together with all approved samples, Submittals and a counterpart of all approved Shop Drawings will be available to Professional for reference. Upon completion of the Work and prior to final payment, these record documents, samples, Shop Drawings and Submittals will be delivered to Professional for Owner.

6.19 Safety and Protection

A. Contractor shall be solely responsible for initiating, maintaining and supervising all safety precautions and programs in connection with the work. Contractor shall take all necessary precautions for the safety of, and provide the necessary protection to prevent damage, injury or loss to:

1. all employees on the Work and other persons and organizations who may be affected thereby;
2. all the Work and materials and equipment to be incorporated therein, whether in storage on or off the site; and
3. other property at the site or adjacent thereto, including trees, shrubs, lawns, walks, pavements, roadways, structures, utilities and Underground Facilities not designated for removal, relocation or replacement in the course of construction.
4. Contractor shall comply with all applicable Laws and Regulations of any public body having jurisdiction for the safety of persons or property or to protect them from damage, injury or loss; and shall erect and maintain all necessary safeguards for such safety and protection. Contractor shall notify owners of adjacent property and of Underground Facilities and utility owners when prosecution of the Work may

affect them, and shall cooperate with them in the protection, removal, relocation and replacement of their property.

B. All damage, injury or loss to any property referred to in Paragraph 6.19 A.2. and 6.19 A.3. caused, directly or indirectly, in whole or in part, by Contractor, any Subcontractor, Supplier or any other person or organization directly or indirectly employed by any of them to perform or furnish any of the Work or anyone for whose acts any of them may be liable, shall be remedied by Contractor (except damage or loss solely attributable to the fault of Owner or Professional or anyone employed by either of them or anyone for whose acts either of them may be liable, and not attributable, directly or indirectly, in whole or in part, to the fault or negligence of Contractor).

C. The Contractor shall be solely responsible for materials delivered and Work performed until completion and final acceptance of the entire construction thereof. The Contractor shall bear the risk of injury, loss or damage to any and all parts of the Work for whatever cause, whether arising from the execution or from the non-execution of Work. The Contractor shall promptly rebuild, repair or restore Work and materials which have been damaged or destroyed from any causes before Final Completion, and shall bear the expense thereof. The Contractor shall provide security and drainage and erect temporary structures as necessary to protect the Work and materials from damage, including damage from water, flooding, wetness, temperature, dust, environmental conditions and all reasonably anticipated risks. The Contractor shall be responsible for materials not delivered to the Work site for which any progress payment has been made to the same extent as if the materials were so delivered.

6.20 Safety Representative

A. Contractor shall designate a responsible representative at the site whose duty shall be the prevention of accidents. This person shall be Contractor's superintendent unless otherwise designated in writing by Contractor to Owner.

6.21 Emergencies

A. In emergencies affecting the safety or protection of persons or the Work or property at the site or adjacent thereto, Contractor, without special instruction or authorization from Professional or Owner, is obligated to act to prevent threatened damage, injury or loss. Contractor shall give Professional prompt written notice if Contractor believes that any significant changes in the Work or variations from the Contract Documents have been caused thereby. If Professional determines that a change in the Contract Documents is required because of the action taken in response to an emergency, a Work Directive Change or Change Order will be issued to document the consequences of the changes or variations.

6.22 Submittals

A. Shop Drawings, Product Data, Samples and similar submittals (collectively referred to as "Submittals") are not Contract Documents. The purpose of their submittal is to demonstrate for those portions of the Work for which Submittals are required the way the Contractor proposes to conform to the information given and the design concept expressed in the Contract Documents.

B. After checking and verifying all field measurements and after complying with applicable procedures specified in the Contract Documents, Contractor shall submit to Professional for review and approval in accordance with the accepted schedule of Submittals, or for other appropriate action if so indicated in the Supplementary Conditions, five (5) copies (unless otherwise specified in the General Requirements) of all Shop Drawings, which will bear a stamp or specific written indication that Contractor has satisfied Contractor's responsibilities under the Contract Documents with respect to the review of the submission. All submissions will be identified as Professional may require for tracking. The data shown on the Shop Drawings will be complete with respect to quantities, dimensions, specified performance and design criteria, materials and similar data to enable Professional to review the information as required.

C. Contractor shall also submit to Professional for review and approval, with such promptness as to cause no delay in Work, all Samples, Product Data and other similar Submittals required by the Contract Documents in accordance with the Schedule for Submittals. All Samples and Product Data will have been checked by and accompanied with a specific written indication that Contractor has satisfied Contractor's responsibilities under the Contract Documents with respect to the review of the submission and will be identified clearly as to material, Supplier, pertinent data such as catalog numbers and the use for which intended.

D. When professional certification of performance criteria of materials, systems, or equipment is required by the Contract Documents, the Contractor shall provide the person or party providing the certification with full information on the relevant performance requirements and on the materials, systems, or equipment that are expected to operate at the Project site. The certification shall be based on performance under the operating conditions generally prevailing or expected at the Project site. All certificates from persons or entities other than Contractor shall be endorsed by Contractor and Contractor shall submit such certificates as its own.

E. The Contractor represents and warrants that all Shop Drawings shall be prepared by persons and entities possessing expertise and experience in the trade for which the Shop Drawing is prepared and, if required by the Contract Documents, or the Professional or applicable Laws and Regulations, by a licensed engineer or other design professional.

F. Before submission of each Submittal Contractor shall have determined and verified all quantities, dimensions, specified performance criteria, installation requirements, materials, catalog numbers and similar data with respect thereto and reviewed or coordinated each Submittal with other Submittals and with the requirements of the Work and the Contract Documents.

G. By approving and submitting to Professional any Submittals, the Contractor represents such Submittals strictly comply with the requirements of the Contract Documents and that the Contractor has determined and verified field measurements and field construction criteria related thereto, that materials are fit for their intended use and that the fabrication, shipping, handling, storage, assembly and installation of all materials, systems and equipment are in accordance with best practices in the industry and are in strict compliance with any applicable requirements of the Contract Documents. Contractor shall also coordinate each Submittal with other Submittals.

H. Contractor shall be responsible for the correctness and accuracy of the dimensions, measurements and other information contained in the Submittals.

I. Each Submittal will bear a stamp or specific indication that the Submittal complies with the Contract Documents and Contractor has satisfied its obligations under the Contract Documents with respect to Contractor's review and approval of that Submittal. Each Submittal shall bear the signature of the representative of Contractor who approved the Submittal, together with the Contractor's name and Project identification.

J. The Contractor shall perform no portion of the Work requiring submittal and review of Submittals until the respective submittal has been approved by the Professional. Such Work shall be in accordance with approved Submittals.

K. At the time of each submission, Contractor shall give Professional specific written notice of each variation that the Submittals may have from the requirements of the Contract Documents, and, in addition, shall cause a specific notation to be made on each Shop Drawing submitted to Professional for review and approval of each such variation.

L. Professional's review and approval will be for conformance with the design concept of the Project and for compliance with the information given in the Contract Documents and shall not extend to means, methods, techniques, sequences or procedures of construction (except where a specific means, method, technique, sequence or procedure of construction is indicated in or required by the Contract Documents) or to safety precautions or programs incident thereto. The review and approval of a separate item as such will not indicate approval of the assembly in which the item functions.

M. Contractor shall make corrections required by Professional and shall return the required number of corrected copies of Shop Drawings and other Submittals and submit as required new Submittals for review and approval. Contractor shall direct specific attention in writing to revisions on the Submittals other than the revisions called for by Professional on previous Submittals.

N. The Contractor shall direct specific attention, in writing or on resubmitted Shop Drawings, Product Data, Samples or similar submittals, to revisions other than those requested by the Professional on previous Submittals.

O. Professional's review and approval of Submittals shall not relieve Contractor from responsibility for any variation from the requirements of the Contract Documents unless Contractor has in writing called Professional's attention to each such variation at the time of submission as required by Paragraph 6.23 K. and Professional has given written approval of each such variation by a specific written notation thereof incorporated in or accompanying the Submittal approval; nor will any approval by Professional relieve Contractor from responsibility for errors or omissions in the Submittals or from responsibility for having complied with the provisions of Section 6.23. In the event Contractor fails to submit any Submittals within the time required in the Contract Documents or submits inadequate or incorrect Submittals, Contractor shall be liable for all additional costs and damage suffered by Owner as a result thereof.

P. Where a Submittal or sample is required by the Specifications, any related Work performed prior to Professional's review and approval of the pertinent submission will be the sole expense and responsibility of Contractor.

6.23 Contractor's Warranty

A. In addition to all other warranties implied by law or expressed in the Contract Documents or elsewhere, the Contractor warrants to Owner that:

1. the materials and equipment furnished under the Contract will be of the most suitable grade of their respective kinds for the purposes intended, fit and sufficient for the purpose intended, merchantable, free from defects in material and workmanship, new, and in strict conformance with the Contract Documents; and

2. the Work will be executed in a workmanlike manner, in the best manner known to each respective trade, free of defects in material and workmanship, of the highest quality in the industry; and in strict conformance with the Contract Documents.

B. The above warranties are not intended as a limitation, but are in addition to, and not in lieu of, all other express warranties set forth in this Contract and such other warranties as are implied by law, in equity, custom, and usage of trade. The Contractor, and its surety or sureties, if any, shall be liable for the satisfaction and full performance of the warranties set forth herein.

C. The Contractor's warranties above shall not be affected by the specification of a product or procedure unless Contractor objects in writing promptly, and in any event before performing the Work in question affected by or related to such product or procedure, and advises the and Professional in writing of possible substitute products or procedures which will not affect the warranty.

D. Contractor shall assign to Owner all manufacturer, supplier or installer's warranties upon Final Completion of the Work; provided, however, the Contractor's warranties provided in this Section 6.23 and other provisions of the Contract Documents shall not be affected, diminished or restricted by the limitations, restrictions, or conditions of a manufacturer, supplier or installer's warranty, including, but not limited to, the expiration of any Uniform Commercial Code statute of limitations. Inability or refusal of a Subcontractor, lower-tier Subcontractor, supplier or installer furnishing defective Work to correct or warrant such Work shall not relieve Contractor of its responsibility for the warranties set forth above and in other provisions of the Contract Documents.

E. Contractor's obligation to perform and complete the Work in strict accordance with the Contract Documents shall be absolute. None of the following shall constitute an acceptance of Work that is not in strict accordance with the Contract Documents or a release of Contractor's obligation to perform the Work in strict accordance with the Contract Documents:

1. observations or inspections by the Professional;
2. approval of any progress or final payment by the Professional;
3. the issuance of a certificate of Substantial or Final Completion or any payment by the Owner to Contractor under the Contract Documents;
4. use or occupancy of the Work or any part thereof by the Owner;
5. any acceptance by the Owner or any failure to do so;
6. any review or approval of Shop Drawings or other Submittal by the Professional;
7. any inspection, test or approval by others; or
8. any correction of defective Work by Owner.

F. The Contractor shall defend, indemnify, and save harmless the Owner from any and all loss, damages, costs, and attorneys' fees suffered or incurred on account of any breach of the aforesaid warranties, obligations and covenants.

6.24 Continuing the Work

A. Contractor shall carry on the Work and adhere to the progress schedule during all disputes or disagreements with Owner. No Work shall be delayed or postponed pending resolution of any disputes or disagreements, except as Contractor and Owner may otherwise agree in writing.

6.25 Indemnification

A. To the fullest extent permitted by law, the Contractor shall defend, indemnify, and hold harmless the Owner, the Professional, Professional's consultants, and the agents, employees, representatives, insurers and re-insurers of any of the foregoing (hereafter collectively referred to as the "Indemnitees") from and against claims, damages (including loss of use of the Work itself), punitive damages, penalties and civil fines unless expressly prohibited by law, losses and expenses, including, but not limited to, attorneys' fees, arising out of or resulting from performance of the Work to the extent caused in whole or in part by negligent acts or omissions or other fault of Contractor, a Subcontractor of any tier, Supplier or anyone directly or indirectly employed by them or anyone for whose acts they may be liable, regardless of whether or not such claim, damage, loss, or expense is caused in part

by the negligent acts or omissions or other fault of a party indemnified hereunder. The Contractor's obligations hereunder are in addition to and shall not be construed to negate, abridge, or reduce other rights or obligations of indemnity that the Owner may possess. If one or more of the Indemnitees demand performance by the Contractor of obligations under this paragraph or other provisions of the Contract Documents and if Contractor refuses to assume or perform, or delays in assuming or performing Contractor's obligations, Contractor shall pay each Indemnitee who has made such demand its respective attorneys' fees, costs, and other expenses incurred in enforcing this provision. The defense and indemnity required herein shall, however, be a binding obligation upon Contractor whether or not an Indemnitee has made such demand. Even if a defense is successful to a claim or demand for which Contractor is obligated to indemnify the Indemnitees from under this Paragraph, Contractor shall remain liable for all costs of defense.

B. The indemnity obligations of Contractor under this Section 6.25 shall survive termination of this Contract or final payment thereunder. In the event of any claim or demand made against any party which is entitled to be indemnified hereunder, the Owner may in its sole discretion reserve, return or apply any monies due or to become due the Contractor under the Contract for the purpose of resolving such claims; provided, however, that the Owner may release such funds if the Contractor provides the Owner with reasonable assurance of protection of the Owner's interests. The Owner shall in its sole discretion determine if such assurances are reasonable. Owner reserves the right to control the defense and settlement of any claim, action or proceeding which Contractor has an obligation to indemnify the Indemnitees against under this Section 6.25.

C. In claims against any person or entity indemnified under this Section 6.25 by an employee of the Contractor, a Subcontractor of any tier, a Supplier, or anyone directly or indirectly employed by them or anyone for whose acts they may be liable, the indemnification obligation under this Section 6.25 shall not be limited by a limitation on amount or type of damages, compensation or benefits payable by or for the Contractor a Subcontractor of any tier or Supplier under workers' or workmen's compensation acts, disability benefit acts or other employee benefit acts.

6.26 Survival of Obligations

A. All representation, indemnifications, warranties and guarantees made in, required by or given in accordance with the Contract Documents, as well as all continuing obligations indicated in the Contract Documents, as well as all continuing obligations indicated in the Contract Documents, will survive final payment, completion and acceptance of the Work and termination of completion of the Agreement.

ARTICLE 7- OTHER WORK

7.01 Related Work at Site

A. Owner may perform other work related to the Project at the site by Owner's own forces, have other work performed by utility owners or let other direct contracts therefor which shall contain General Conditions similar to these. If the fact that such other work is to be performed was not noted in the Contract Documents, written notice thereof will be given to Contractor prior to starting any such other work. In such events, Contractor must anticipate in its scheduling that its Work may be interfered with or delayed by such other Work. Contractor shall fully cooperate and coordinate its Work with the other work to avoid or mitigate such interferences or delays.

B. Contractor shall afford each utility owner and other contractor who is a party to such a direct contract (or Owner, if Owner is performing the additional work with Owner's employees) proper and safe access to the site and a reasonable opportunity for the introduction and storage of materials and equipment and the execution of such work, and shall properly connect and coordinate the Work with theirs. Contractor shall do all cutting, fitting and patching of the Work that may be required to make its several parts come together properly and integrate with such other work. Contractor shall not endanger any work of others by cutting, excavating or otherwise altering their work and will only cut or alter their work with the written consent of Professional and the others whose work will be affected. The duties and responsibilities of Contractor under this paragraph are for the benefit of such utility owners and other contractors.

C. If any part of Contractor's Work depends on proper execution or results upon the work of any such other contractor or utility owner (or Owner), Contractor shall inspect and promptly report to Professional in writing any delays, defects or deficiencies in such work that render it unavailable or unsuitable for such proper execution and results Contractor's failure to report this will constitute an acceptance of the other work as fit and proper for integration with Contractor's Work except for latent or non-apparent deficiencies in the other work.

7.02 Coordination

A. If Owner contracts with others for the performance of other work on the Project site, the person or organization who will have authority and responsibility for coordination of the activities among the various prime contractors will be identified in the **Supplementary Conditions**, and the specific matters to be covered by such authority and responsibility will be itemized, and the extent of such authority and responsibilities will be provided in

the Supplementary Conditions. Unless otherwise provided in the Supplementary Conditions, neither Owner nor Professional shall have any authority or responsibility in respect of such coordination.

7.03 Liability

A. Contractor shall not delay a separate contractor by neglecting to perform its Work at the proper time. Contractor shall be required to coordinate its Work with separate contractors so as to afford separate contractors a reasonable and safe opportunity for execution of their work. Any costs caused by delays or improperly timed activities or defective construction shall be borne by the party responsible therefor.

B. Contractor shall be responsible for damage to Owner's or separate contractors' property caused by Contractor or any person or entity for whose acts or omissions Contractor may be liable.

C. In the event Contractor is delayed or damaged by the activities, fault, negligent acts or omissions, delays or improperly timed activities, or defective construction of any separate contractor of Owner or person or entity for whose acts or omissions the separate contractor may be liable, Contractor agrees to solely look to the separate contractor for compensation as a result of such activities, fault, negligent acts or omissions, delays or improperly timed activities, or defective construction. Contractor shall be considered a third party beneficiary of any contract between Owner and any separate contractor for the Project solely for the purpose of recovering damages from such separate contractor which are caused by the activities, fault, negligent acts or omissions, delays or improperly timed activities, or defective construction of such separate contractor of Owner or any person or entity for whose acts or omissions such separate contractor may be liable.

D. Contractor shall be responsible for any damages of separate contractors of Owner caused by the activities, fault, negligent acts or omissions, delays or improperly timed activities, or defective construction of Contractor or of any person or entity for whose acts or omissions Contractor is liable. Contractor acknowledges that such separate contractors shall be considered third party beneficiaries of this Contract for the sole purpose of allowing any separate contractor the right to directly recover damages from Contractor which are caused by the activities, fault, negligent acts or omissions, delays or improperly timed activities, or defective construction of Contractor or of any person or entity for whose acts or omissions Contractor may be liable.

E. Should Contractor cause any damage to a separate contractor of the Owner, Contractor shall promptly attempt to settle with such separate contractor in good faith. Contractor shall defend, indemnify and hold harmless Owner, and its agents, representatives and employees from and against any claims of separate contractors in accordance with Section 6.25.

F. If a dispute arises among the Contractor, separate contractors and the Owner as to the responsibility under their respective contracts for maintaining the premises and surrounding area free from waste materials and rubbish, they may clean up and allocate the cost among those responsible as Owner determines to be just.

ARTICLE 8 - OWNER'S RESPONSIBILITIES

8.01 Termination of Professional

A. In case of termination of the employment of Professional, Owner shall appoint a design professional whose status under the Contract Documents shall be that of the former Professional.

8.02 Data and Information

A. When requested in writing by Contractor, Owner shall furnish the data required of Owner under the Contract Documents promptly.

8.03 Limitations on Owner's Responsibilities

A. The Owner shall not supervise, direct, or have control or authority over, nor be responsible for, Contractor's means, methods, techniques, sequences, or procedures of construction, or the safety precautions and programs incident thereto, or for any failure of Contractor to comply with Laws and Regulations applicable to performance of the Work. Owner will not be responsible for Contractor's failure to perform the Work in accordance with the Contract Documents.

ARTICLE 9 - PROFESSIONAL'S STATUS DURING CONSTRUCTION

9.01 General

A. Professional will be Owner's representative during the construction period. The duties and responsibilities and the limitations of authority of Professional as Owner's representative during construction are set forth in the Contract Documents and shall not be extended without written consent of Owner and Professional.

9.02 Visits to Site

A. Professional will make visits to the site at intervals appropriate to the various stages of construction to observe the progress and quality of the executed Work and to determine, in general, if the Work is proceeding in accordance with the Contract Documents. On the basis of such visits and on-site observations, Professional will keep Owner informed of the progress of the Work and will endeavor to guard Owner against defects and deficiencies in the Work.

9.03 Project Representation

A. If Owner and Engineer agree, Engineer will furnish a Resident Project Representative to assist Engineer in observing the performance of the Work. The duties, responsibilities and limitations of authority of any such Resident Project Representative and assistants will be as provided in the Supplementary Conditions. If Owner designates another agent to represent Owner at the site who is not Engineer's agent or employee, the duties, responsibilities and limitations of authority of such other person will be as provided in the Supplementary Conditions.

9.04 Clarifications and Interpretations

A. Professional will issue with reasonable promptness such written clarifications or interpretations of the requirements of the Contract Documents (in the form of Drawings or otherwise) as Professional may determine necessary, which shall be consistent with or reasonably inferable from the overall intent of the Contract Documents. If Contractor believes that a written clarification or interpretation justifies an increase in the Contract Price or an extension of the Contract Times and the parties are unable to agree to the amount or extent thereof, Contractor may make a claim therefor as provided in Articles 11 or Article 12.

9.05 Authorized Variations in Work

A. Professional may authorize minor variations in the Work from the requirements of the Contract Documents that do not involve an adjustment in the Contract Price or the Contract Times and are consistent with the overall intent of the Contract Documents. These may be accomplished by a Field Order and will be binding on Owner, and also on Contractor who shall perform the Work involved promptly. The Professional shall not have the authority to order changes without the agreement of Owner which affect the Contract Price or Contract Times.

9.06 Rejecting Defective Work

A. Professional will have authority to disapprove or reject Work which Professional believes to be defective and will also have authority to require special inspection or testing of the Work as provided in Paragraph 13.03 B., whether or not the Work is fabricated, installed or completed.

9.07 Submittals

A. In connection with Professional's responsibility for Submittals, see Section 6.22 inclusive.

9.08 Change Orders

A. In connection with Professional's responsibilities as to Change Orders, see Articles 10, 11 and 12.

9.09 Payments

A. In connection with Professional's responsibilities in respect of Applications for Payment, see Article 14.

9.10 Determinations for Unit Prices

A. Professional will determine the actual quantities and classifications of Unit Price Work performed by Contractor. Professional will review with Contractor's representative preliminary determinations on such matters before rendering a written decision thereon (by recommendation of an Application for Payment or otherwise). Professional's written decisions thereon will be final and binding upon Contractor, unless, within ten (10) days after the date of any such decision, Contractor delivers to Owner and Professional a written objection to such determination.

9.11 Limitations on Professional's Responsibilities

A. Neither Professional's authority to act under this Article 9 or elsewhere in the Contract Documents nor any decision made by Professional in good faith either to exercise or not exercise such authority shall give rise to any duty or responsibility of Professional to Contractor, any Subcontractor, any Supplier, or any other person or organization performing any of the Work, or to any surety for any of them.

9.12 Terminology

A. Whenever in the Contract Documents the terms "as ordered", "as directed", "as required", "as allowed", "as approved" or terms of like effect or import are used, or the adjectives "reasonable", "suitable", "acceptable", "proper" or "satisfactory" or adjectives of like effect or import are used to describe a requirement, direction, review or judgment of Professional as to the Work, it is intended that such requirement, direction, review or judgment will be solely to evaluate the Work for compliance with the Contract Documents (unless there is a specific statement indicating otherwise). The use of any such term or adjective shall not be effective to assign to Professional any duty or authority to supervise or direct the furnishing or performance of the Work.

ARTICLE 10 – CHANGES IN THE WORK AND CLAIMS

10.01 Authorized Changes in Work

A. Without invalidating the Agreement and without notice to any surety, Owner may, at any time or from time to time, order additions, deletions or revisions in the Work. Such additions, deletions or revisions will be authorized by a Written Amendment, a Change Order, or a Work Change Directive or Field Order. Upon receipt of any such document, Contractor shall promptly proceed with the Work involved, which will be performed under the applicable conditions of the Contract Documents (except as otherwise specifically provided).

B. A Change Order is a written instrument signed by the Owner and Contractor, stating their agreement upon all of the following:

1. a change in the Work;
2. the amount of the adjustment in the Contract Price, if any; and
3. the extent of the adjustment in the Contract Time, if any.

C. Agreement on any Change Order shall constitute a final settlement of all matters relating to the change in the Work which is the subject of the Change Order, including, but not limited to, all direct and indirect costs associated with such change and any and all adjustments to the Contract Price and the Contract Times and any applicable Milestone Dates. In the event a Change Order increases the Contract Price, Contractor shall include the Work covered by such Change Orders in Applications for Payment as if such Work were originally part of the Contract Documents.

D. A Work Change Directive is a written order approved by Professional and issued by Owner directing a change in the Work and stating a proposed basis for adjustment in the Contract Price and/or Contract Times. A Work Change Directive shall be used in the absence of total agreement on the terms of a Change Order. Upon receipt of a Work Change Directive, the Contractor shall proceed with the change in the Work involved and advise Owner and Professional of Contractor's agreement or disagreement with the method, if any, provided in the Work Change Directive for determining the proposed adjustment in the Contract Price or Contract Times. A Construction Change Directive signed by the Contractor indicates the agreement of the Contractor therewith, including adjustment in Contract Price and Contract Times or the method for determining them. Such agreement shall be effective immediately and shall be recorded as a Change Order.

E. The Professional will have authority to issue order changes in the Work not involving adjustment in the Contract Price or extension of the Contract Times and not inconsistent with the intent of the Contract Documents. Such minor changes shall be effectuated by a written Field Order and shall be binding on Owner and Contractor. The Contractor shall carry out such changes set forth in a Field Order promptly.

10.02 Unauthorized Changes in Work

A. Contractor shall not be entitled to an increase in the Contract Price or an extension of the Contract Times with respect to any Work performed that is not required by the Contract Documents as amended, modified and supplemented by a Modification, except in the case of an emergency as provided in Article 6.21 and except in the case of uncovering Work as provided in Section 13.03 B.

10.03 Notice to Surety

A. If notice of any change affecting the general scope of the Work or the provisions of the Contract Documents (including, but not limited to, Contract Price or Contract Times) is required by the Surety. Such notice shall

10.04 Claims

A. A Claim is a demand or assertion by Contractor seeking, as a matter of right, adjustment or interpretation of Contract terms, payment of money, extension of time or any other relief with respect to the terms of the Contract. The term "Claim(s)" also includes demands and assertions of Contractor arising out of or relating to the

Contract Documents, including Claims based upon breach of contract, mistake, misrepresentation, or other cause for Contract Modification or rescission. Claims must be made by written notice in strict accordance with the Contract Documents. Contractor shall have the responsibility to substantiate Claims. A Claim for an adjustment in the Contract Price shall be submitted in accordance with Paragraph 11.02 B. A Claim for each adjustment in the Contract Times shall be submitted in accordance with Paragraph 12.01 A.

ARTICLE 11 - CHANGE OF CONTRACT PRICE

11.01 Contract Price

A. The Contract Price constitutes the total compensation (subject to authorized adjustments) payable to Contractor for performing the Work. All duties, responsibilities and obligations assigned to or undertaken by Contractor shall be at Contractor's expense without change in the Contract Price.

11.02 Change

A. The Contract Price may only be changed by a Change Order or by a Written Amendment. Accordingly, no course of conduct or dealings between the parties, nor express or implied acceptance of alterations or additions to the Work, and no claim that the Owner has been unjustly enriched by any alteration or addition to the Work, whether or not there is, in fact, any unjust enrichment to the Owner, shall be the basis of any Claim to an increase in any amounts due under the Contract Documents.

B. Any claim by Contractor for an adjustment in the Contract Price shall be based on written notice as set forth herein. Any claim for an increase or decrease in the Contract Price by Contractor shall be based on written notice delivered by Contractor to Owner and to Professional promptly (but in no event later than fifteen (15) days) after the occurrence of the event giving rise to the claim and stating the general nature of the claim. Notice of the amount of the claim with supporting data shall be delivered within forty-five (45) days after such occurrence (unless Professional allows an additional period of time to ascertain more accurate data in support of the claim) and shall be accompanied by Contractor's written statement that the amount claimed covers all known amounts (direct, indirect and consequential) to which Contractor is entitled as a result of the occurrence of said event. No claim for an adjustment in the Contract Price by Contractor will be valid if not submitted in accordance with this Paragraph 11.02 B.

C. Any work completed by Contractor not agreed to by Owner in a Change Order, Work Change Directive or a Field Order shall be at Contractor's sole cost and expense and shall be deemed a waiver of all rights the Contractor may have for any adjustment in the Contract Price or Contract Times.

11.03 Determination of Adjustment

A. The value of the Work covered by a Change Order or of any Claim for an increase or decrease in the Contract Price shall be determined by Owner in one of the following ways:

1. Where the Work involved is covered by unit prices contained in the Contract Documents, by application of unit prices contained in the Contract Documents to the quantities of the items involved in the change.
2. By mutual acceptance of a lump sum (which may include an allowance for overhead and profit not necessarily in accordance with Paragraph 11.06 A.2.); or
3. On the basis of the Cost of the Work (determined as provided in Paragraphs 11.04 and 11.05) plus a Contractor's Fee for overhead and profit (determined as provided in Paragraph 11.06).

11.04 Cost of the Work

A. The term Cost of the Work means the sum of all costs necessarily incurred and paid by Contractor in the proper performance of the Work. When the value of any work covered by a Change Order or when a Claim for an adjustment in Contract Price is determined on the basis of Cost of the Work, the costs to be reimbursed to Contractor will be only those additional or incremental costs required because of the change in the Work or because of the event giving rise to the Claim. Except as otherwise may be agreed to in writing by Owner, such costs shall be in amounts no higher than those prevailing in the locality of the Project, shall include only the following items and shall not include any of the costs described in Paragraph 11.05:

1. Payroll costs for employees in the direct employ of Contractor in the performance of the Work under schedules of job classifications agreed upon by Owner and Contractor. Payroll costs for employees not employed full time on the Work shall be apportioned on the basis of their time spent on the Work. Payroll costs shall include, but not be limited to, salaries and wages plus the cost of fringe benefits which shall include social security contributions, unemployment, excise and payroll taxes, workers' or workmen's compensation, health and retirement benefits, bonuses, sick leave, vacation and holiday pay applicable thereto. Such employees shall include superintendents and foremen at the site. The expenses of

performing Work after regular working hours, on Saturday, Sunday or legal holidays, shall be included in the above to the extent authorized by Owner.

2. Cost of all materials and equipment furnished and incorporated in the Work, including costs of transportation and storage thereof, and Suppliers' field services required in connection therewith. All cash discounts shall accrue to Contractor unless Owner deposits funds with Contractor with which to make payments, in which case the cash discounts shall accrue to Owner. All trade discounts, rebates and refunds and all returns from sale of surplus materials and equipment shall accrue to Owner, and Contractor shall make provisions so that they may be obtained.

3. Payments made by Contractor to the Subcontractors for Work performed by Subcontractors. If required by Owner, Contractor shall obtain competitive bids from Subcontractors acceptable to Contractor and shall deliver such bids to Owner who will then determine, with the advice of Professional, which bids will be accepted. If a subcontract provides that the Subcontractor is to be paid on the basis of Cost of the Work Plus a Fee, the Subcontractor's Cost of the Work shall be determined in the same manner as Contractor's Cost of the Work. All subcontracts shall be subject to the other provisions of the Contract Documents insofar as applicable.

4. Cost of special consultants (including but not limited to engineers, Professionals, testing laboratories, surveyors, attorneys and accountants) employed for services specifically related to the Work.

5. Supplemental costs including the following

a. Cost, including transportation and maintenance, of all materials, supplies, equipment, machinery, appliances, office and temporary facilities at the site and hand tools not owned by the workers, which are consumed in the performance of the Work, and cost less market value of such items used but not consumed which remain the property of Contractor.

b. Rentals of all construction equipment and machinery and the parts thereof whether rented from Contractor or others in accordance with rental agreements approved by Owner with the advice of Professional, and the cost of transportation, loading, unloading, installation, dismantling and removal thereof - all in accordance with terms of said rental agreements. The rental of any such equipment, machinery or parts shall cease when the use thereof is no longer necessary for the Work.

c. Sales, consumer, use or similar taxes related to the Work, and for which Contractor is liable, imposed by Laws and Regulations.

6. Cost of premiums for additional Bonds and insurance required because of changes in the Work and premiums for property insurance coverage within the limits of the deductible amounts established by Owner in accordance with Paragraph 5.07.

11.05 Costs Excluded

A. The term Cost of the Work shall not include any of the following:

1. Payroll costs and other compensation of Contractor's officers, executives, principals (of partnership and sole proprietorships), general managers, engineers, Professionals, estimators, attorneys, auditors, accountants, purchasing and contracting agents, expeditors, timekeepers, clerks and other personnel employed by Contractor whether at the site or in Contractor's principal or a branch office for general administration of the Work and not specifically included in the agreed upon schedule of job classifications referred to in Paragraph 11.04 A.1. or specifically covered by Paragraph 11.04 A.4. all of which are to be considered administrative costs covered by the Contractor's Fee.

2. Expenses of Contractor's principal and branch offices other than Contractor's office at the site.

3. Any part of Contractor's capital expenses, including interest on Contractor's capital employed for the Work and charges against Contractor for delinquent payments.

4. Cost of premiums for all Bonds and for all insurance whether or not Contractor is required by the Contract Documents to purchase and maintain the same (except for the cost of premiums covered by Paragraph 11.04. A.6.).

5. Costs due to the negligence of Contractor, any Subcontractor, or anyone directly or indirectly employed by any of them or for whose acts any of them may be liable including but not limited to, the

correction of defective Work, disposal of materials or equipment wrongly supplied and making good any damage to property.

6. Other overhead or general expense costs of any kind and the costs of any item not specifically and expressly included in Section 11.04.

11.06 Contractor's Fee

A. The Contractor's Fee allowed to Contractor for overhead and profit shall be determined as follows:

1. a mutually acceptable fixed fee;
2. if a fixed fee is not agreed upon, then a fee based on the following percentages of the various portions of the Cost of the Work:
 - a. for costs incurred under Paragraphs 11.04 A.1. and 11.04 A.2., the Contractor's Fee shall be ten percent;
 - b. for costs incurred under Paragraph 11.04 A.3., the Contractor's Fee shall be five percent. Where one or more tiers of subcontracts are on the basis of Cost of the Work plus a fee and no fixed fee is agreed upon, the intent of this Section is that the Subcontractor who actually performs the Work, at whatever tier, will be paid a fee of ten percent (10%) of the costs incurred by Subcontractor under Paragraphs 11.04 A.1. or 11.04 A.2. and that any higher tier Subcontractor and Contractor will each be paid a fee of five percent (5%) of the amount paid to the next lower tier Subcontractor. In no event shall there be more than three-mark ups of cost on extract work regardless of the number of tiers of Subcontractors;
 - c. no fee shall be payable on the basis of costs itemized under Paragraphs 11.04. A.4., 11.04 A.5. and 11.04.A6;
 - d. the amount of credit to be allowed by Contractor to Owner for any such change which results in a net decrease in cost will be the amount of the actual net decrease plus a deduction in Contractor's Fee by an amount equal to ten percent (10%) of the net decrease; and
 - e. when both additions and credits are involved in any one change, the adjustment in Contractor's Fee shall be computed on the basis of the net change in accordance with Paragraphs 11.04 A.2.a. through 11.04 A.2.d., inclusive.

11.07 Submission of Itemized Costs

A. Whenever the cost of any Work is to be determined pursuant to Article 11.04, Contractor will submit in a form acceptable to Owner and Professional an itemized cost breakdown together with supporting data.

11.08 Allowance

A. It is understood that Contractor has included in the Contract Price all allowances (if any) so named in the Contract Documents and shall cause the Work so covered to be done by such Subcontractors or Suppliers and for such sums within the limit of the allowances as may be acceptable to Professional. Contractor agrees that:

1. The allowances include the cost to Contractor (less any applicable trade discount) of materials and equipment required by the allowances to be delivered at the site, and all applicable taxes; and
2. Contractor's cost for unloading and handling material on the site, labor, installation costs, overhead, profit and other expenses contemplated for the allowances have been included in the Contract Price and not in the allowances. No demand for additional payment on account of any thereof will be valid.
3. Prior to final payment, an appropriate Change Order will be issued as recommended by Professional to reflect actual amounts due Contractor on account of Work covered by allowances, and the Contract Price shall be correspondingly adjusted.

ARTICLE 12 - CHANGE OF CONTRACT TIMES

12.01 Claims for Additional Time

A. The Contract Times may only be changed by a Change Order or a Written Amendment. Any claim by Contractor for an adjustment in the Contract Price shall be based on written notice as set forth herein. Any claim for an extension or shortening of the Contract Times shall be based on written notice delivered by Contractor to Owner and to Professional promptly (but in no event later than fifteen (15) days) after the occurrence of the event giving rise to the claim and stating the general nature of the claim. Notice of the extent of the claim with supporting data shall be delivered within forty-five (45) days after such occurrence (unless Professional allows an additional period of time to ascertain more accurate data in support of the claim) and shall be accompanied by the claimant's written statement that the adjustment claimed is the entire adjustment to which the claimant has reason to believe it is entitled as a result of the occurrence of said event. No claim for an adjustment in the Contract Times will be valid if not submitted in accordance with the requirements of this Paragraph 12.01 A.

B. If abnormal weather conditions are the basis for a Claim for additional time, such Claim shall be documented by the Contractor by data acceptable to the Professional substantiating that weather conditions were abnormal for the period of time in question, and could not have been reasonably anticipated, and that weather conditions had an adverse effect on the scheduled construction. Requests for extension of the scheduled Completion Date(s) or Milestone Dates due to adverse weather conditions shall include reliable or official climatological reports for the months involved, plus a report indicating the average precipitation, temperature, and other climatological data for the past ten (10) years from a reporting station near the Project site. The ten-year average will be the basis for determining the number of adverse weather days and the effect resulting therefrom on construction which Contractor would normally expect to encounter.

12.02 Delays of Contract Times

A. If the Contractor is delayed in the commencement or progress of the Work by an act or neglect of the Owner or Professional, or of an employee of either, or by changes in the Work, or by fire, or by unavoidable casualties, acts of God, or abnormal weather conditions established pursuant to Paragraph 12.01 B, or by acts or neglect of utility owners or separate contractors performing other Work as provided in Article 7, the Contract Times and applicable Milestones will be extended in an amount equal to the time lost due to such delay if a Claim is made therefore by Contractor as provided herein. The Contract Times and applicable Milestones will not be extended due to delays within the reasonable control of Contractor. Where Contractor is prevented from completing any part of the Work within the Contract Times or any applicable Milestones due to delay beyond the control of both Owner and Contractor, including but not limited to fires, unavoidable casualties, acts of God, abnormal weather conditions, or acts or neglect of utility owners or separate contractors performing other work as provided for in Article 7, an extension of the Contract Times or any applicable Milestones in an amount equal to the time lost due to such delay shall be Contractor's sole and exclusive remedy for such delay.

B. The Contractor further acknowledges and agrees that adjustments in the Contract Times will be permitted for a delay only to the extent such delay (1) is not caused, or could not have been anticipated, by the Contractor, (2) could not be limited or avoided by the Contractor's timely notice to the Owner of the delay, (3) prevents Contractor from completing its Work by the Contract Time, and (4) is of a duration not less than one (1) day. Delays attributable to and within the control of a Subcontractor or supplier shall not justify an extension of the Contract Times.

12.03 Delay Damages

A. Professional Notwithstanding anything to the contrary in the Contract Documents, an extension in the Contract Times, to the extent permitted under this Article, shall be the sole remedy of the Contractor for any (1) delay in the commencement, prosecution or completion of the Work, (2) hindrance or obstruction in the performance of the Work, or (3) loss of productivity except as set forth below. In no event shall the Contractor be entitled to any compensation or recovery of any damages or any portion of damages resulting from delays caused by or within the control of Contractor or by acts or omissions of Contractor or its Subcontractors of any tier or Supplier or delays beyond the control of both Owner and Contractor. If the Contractor contends that delay, hindrance, obstruction or other adverse condition results from acts or omissions of the Owner, or the Professional, Contractor shall promptly provide written notice to the Owner. Contractor shall only be entitled to an adjustment in the Contract Price to the extent that such acts or omissions continue after the Contractor's written notice to the Owner of such acts or omissions. The Owner's exercise of any of its rights or remedies under the Contract Documents (including, without limitation, ordering changes in the Work, or directing suspension, rescheduling or correction of the Work) regardless of the extent or frequency of the Owner's exercise of such rights or remedies, shall not be the basis of any Claim for an increase in the Contract Price or Contract Times. In the event Contractor is entitled to an adjustment in the Contract Price for any delay, hindrance, obstruction or other adverse condition caused by the acts or omissions of the Owner, or the Professional, Contractor shall only be entitled to its actual direct costs caused thereby and Contractor shall not be entitled to and waives any right to special, indirect, or consequential damages including loss of profits,

loss of savings or revenues, loss of anticipated profits, labor inefficiencies, idle equipment, home office overhead, and similar type of damages.

B. If the Contractor submits a progress report or any construction schedule indicating, or otherwise expressing an intention to achieve completion of the Work prior to any completion date required by the Contract Documents or expiration of the Contract Times, no liability of the Owner to the Contractor for any failure of the Contractor to so complete the Work shall be created or implied. Further, the Contractor acknowledges and agrees that even if Contractor intends or is able to complete the Work prior to the Contract Times, it shall assert no Claim and the Owner shall not be liable to Contractor for any failure of the Contractor, regardless of the cause of the failure, to complete the Work prior to the Contract Times.

12.04 Liquidated Damages

A. If liquidated damages are prescribed in the Agreement, the Owner may deduct from the Contract Price and retain as liquidated damages, and not as penalty or forfeiture, the sum stipulated in the Contract Documents for each calendar day after the date specified for completion of the Project that the entire Work is not substantially complete and/or finally complete.

B. The Professional shall certify the date of Substantial Completion and Final Completion which shall be conclusive and binding on the Owner and Contractor for the purpose of determining whether or not liquidated damages shall be assessed under terms hereof and the total amount due.

C. Liquidated damages or any matter related thereto shall not relieve the Contractor or his surety of any responsibility or obligation under this Contract.

ARTICLE 13 - TESTS AND INSPECTIONS; CORRECTION, REMOVAL OR ACCEPTANCE OF DEFECTIVE WORK

13.01 Access to Work

A. Professional and Professional's representatives, other representatives of Owner, testing agencies and governmental agencies with jurisdictional interests will have access to the Work at reasonable times for their observation, inspecting and testing. Contractor shall provide proper and safe conditions for such access.

13.02 Tests and Inspections

A. Contractor shall give Professional timely notice of readiness of the Work for all required inspections, tests or approvals.

B. Contractor shall employ and pay for the services of an independent testing laboratory to perform all inspections, tests or approvals required by Laws and Regulations or the Contract Documents, except:

1. those costs incurred in connection with tests or inspections conducted pursuant to Paragraph 13.03. B. shall be paid as provided in Paragraph 13.03. B.; and
2. as otherwise specifically provided in the Contract Documents.

C. Without limiting the generality of Paragraph 13.03. B., Contractor shall be responsible for arranging and obtaining and shall pay all costs in connection with any inspections, tests or approvals required for Professional's acceptance of materials or equipment to be incorporated in the Work; or acceptance of materials, mix designs, or equipment submitted for approval prior to Contractor's purchase thereof for incorporation in the Work.

D. All inspections, tests or approvals other than those required by Laws or Regulations of any public body having jurisdiction shall be performed by organizations acceptable to Owner and Professional.

E. Neither observations, inspections, tests or approvals by Professional or others, shall relieve Contractor from Contractor's obligations to perform the Work in accordance with the Contract Documents.

F. If any Work (including the work of others) that is to be inspected, tested, or approved is covered without written concurrence of Professional, it must, if requested by Professional, be uncovered for observation. Such uncovering shall be at Contractor's expense unless Contractor has given Professional timely notice of Contractor's intention to cover the same and Professional has not acted with reasonable promptness in response to such notice.

13.03 Uncovering Work

A. If any Work is covered contrary to the written request of Professional, it must, if requested by Professional, be uncovered for Professional's observation and replaced at Contractor's expense.

B. If Professional considers it necessary or advisable that covered Work be observed by Professional or inspected or tested by others, Contractor, at Professional's request shall uncover, expose or otherwise make available for observation, inspection or testing as Professional may require, that portion of the Work in question, furnishing all necessary labor, material and equipment. If it is found that such Work is defective, Contractor shall bear all direct, indirect and consequential costs of such uncovering, exposure, observation, inspection and testing and of satisfactory reconstruction, (including but not limited to fees and charges of engineers, Professionals, attorneys and other professionals), and Owner shall be entitled to an appropriate decrease in the Contract Price. If, however, such Work is not found to be defective, Contractor shall be allowed an increase in the Contract Price or an extension of the Contract Times, or both, directly attributable to such uncovering, exposure, observation, inspection, testing and reconstruction: and, if the parties are unable to agree as to the amount or extent thereof, Contractor may make a claim therefor as provided in Articles 11 and 12.

13.04 Owner May Stop the Work

A. If the Work is defective, or Contractor fails to supply sufficient skilled workers or suitable materials or equipment, or fails to furnish or perform the Work in such a way that the completed Work will conform to the Contract Documents, Owner may order Contractor to stop the Work, or any portion thereof, until the cause for such order has been eliminated; however, this right of Owner to stop the Work shall not give rise to any duty on the part of Owner to exercise this right for the benefit of Contractor or any Subcontractor, Supplier or any other entity, or any surety for, or employee or agent of any of them.

13.05 Correction or Removal of Defective Work

A. Contractor shall correct all defective Work, whether or not fabricated, installed or completed, or, if the Work has been rejected by Professional, remove it from the Site and replace with nondefective Work. Contractor shall bear all direct, indirect and consequential costs, losses and damages (including but not limited to fees and charges of engineers, attorneys and other professionals) arising out of or relating to such correction or removal (including, but not limited to, all costs of repair and replacement of work of others).

13.06 Guarantee Period

A. If within one year after the date of Substantial Completion or longer period of time as may be prescribed by Laws or Regulations or by the terms of any applicable special guarantee required by the Contract Documents, and/or Change Orders ("Guarantee Period"), any Work is found to be defective, Contractor shall promptly, without cost to the Owner and in accordance with Owner's written instructions, either correct such defective Work, or, if it has been rejected by Owner, remove it from the site and replace it with nondefective Work. If Contractor does not promptly comply with the terms of such instructions, or in an emergency where delay would cause serious risk of loss or damage, Owner may have the defective Work corrected or the rejected Work removed and replaced, and all direct, indirect and consequential costs of such removal and replacement (including but not limited to fees and charges of engineers, attorneys and other professionals) will be paid by Contractor. Nothing contained in this Section 13.06 shall be construed to establish a period of limitation with respect to other obligations which the Contractor might have under the Contract Documents. Establishment of the one (1) year Guarantee Period as described in this Paragraph 13.06 relates only to the specific obligation of the Contractor to correct, remove or replace the Work, and has no relationship to the time within which the obligation to comply with the Contract Documents may be sought to be enforced, nor to the time within which proceedings may be commenced to establish the Contractor's liability with respect to the Contractor's obligations under the Contract Documents. The requirements of Article 13 are in addition to and not in limitation of any of the other requirements of the Contract for warranties or conformance of the Work to the requirements of the Contract Documents.

B. Where defective Work (and damage to other Work resulting therefrom) has been corrected or removed and replaced under this paragraph 13.06, the correction period hereunder with respect to such Work will be extended for an additional period of one (1) year after such correction or removal and replacement has been satisfactorily completed.

C. Contractor's obligations under this paragraph 13.06 are in addition to any other obligation or warranty. The provisions of this Paragraph 13.06 shall not be construed as a substitute for or a waiver of the provisions of any applicable statute of limitation or repose.

13.07 Acceptance of Defective Work

A. If, instead of requiring correction or removal and replacement of defective Work, Owner (and if, prior to Professional's recommendation of final payment, also Professional) prefers to accept it, Owner may do so. Contractor shall bear all direct, indirect and consequential costs attributable to Owner's evaluation of and determination to accept such defective Work (such costs to be approved by Professional as to reasonableness and to include but not be limited to fees and charges of engineers, Professionals, attorneys and other professionals). If any such acceptance occurs prior to Professional's recommendation of final payment, a Change Order will be issued

incorporating the necessary revisions in the Contract Documents with respect to the Work; and Owner shall be entitled to an appropriate decrease in the Contract Price. If the acceptance occurs after such recommendation, an appropriate amount will be paid by Contractor to Owner.

13.08 Owner May Correct Defective Work

A. If Contractor fails within a reasonable time after written notice of Professional to proceed to correct defective Work or to remove and replace rejected Work as required by Professional, or if Contractor fails to perform the Work in accordance with the Contract Documents, or if Contractor fails to comply with any other provision of the Contract Documents, Owner may, after seven days written notice to Contractor, correct and remedy any such deficiency. In exercising the rights and remedies under this paragraph, Owner shall proceed expeditiously.

B. To the extent necessary to complete corrective and remedial action, Owner may exclude Contractor from all or part of the site, take possession of all or part of the Work, and suspend Contractor's services related thereto, take possession of Contractor's tools, appliances, construction equipment and machinery at the site and incorporate in the Work all materials and equipment stored at the site or for which Owner has paid Contractor but which are stored elsewhere. Contractor shall allow Owner, Owners, agents and employees such access to the site as may be necessary to enable Owner to exercise such rights and remedies under this paragraph.

C. All direct, indirect and consequential costs, losses and damages of Owner in exercising the rights and remedies under this Paragraph 13.08 will be charged against Contractor. Such direct, indirect and consequential costs, losses and damages will include, but not be limited to, fees and charges of consultants, Professional, attorneys and other professionals, all court and arbitration costs and all costs of repair and replacement of work of others destroyed or damaged by correction, removal or replacement of Contractor's defective Work. Contractor shall not be allowed an extension of the Contract Times because of any delay in performance of the Work attributable to the exercise by Owner of Owner's rights and remedies hereunder.

D. In the event that the defective Work, equipment or material creates a hazard or an emergency situation, the requirement of seven days written notice may be reduced to notification by telephone or attempt thereof. Hazardous or emergency situations include, but are not limited to: defective traffic control devices, flood control structures and devices; or excavations.

ARTICLE 14 - PAYMENTS TO CONTRACTOR AND COMPLETION

14.01 Contract Price

A. The Owner shall compensate Contractor for all Work described herein and in the Contract Documents the Contract Price set forth in the Agreement, subject to additions and deletions as provided hereunder.

14.02 Basis Of Progress Payments

A. The Schedule of Values, if any, established as provided in the Agreement, shall serve as the basis for progress payments for a lump sum contract and will be incorporated into a form of Application for Payment acceptable to Owner. The values set forth in such schedule shall not be used in any manner as fixing a basis for additions or deletions from the Contract Price. Progress payments on account of Unit Price Work will be based on the number of units completed.

14.03 Applications For Payment

A. In the time set forth in Paragraph 14.06 B., the Contractor shall submit to the Owner and the Professional an itemized Application for Payment in accordance with the Contract Documents. Such application shall be notarized, if required, and supported by such data substantiating the Contractor's right to payment as the Owner or Professional may require, such as copies of requisitions from Subcontractors and material suppliers, and reflecting retainage as provided for herein.

B. Such applications may not include requests for payment of amounts the Contractor does not intend to pay to a Subcontractor or material supplier because of a dispute or other reason.

C. Each Application for Payment shall be accompanied by the following, all in form and substance satisfactory to the Owner:

1. Contractor's updated schedule and a progress report setting forth in detail the actual progress to date (in terms of percent complete) and the scheduled or planned progress, a listing of the value of material on hand included in the Application and other data specified in the Specifications;

2. Weekly employee payrolls for Contractor and all Subcontractors. Each Application for Payment shall be accompanied by a certified copy of employee payrolls, submitted on Federal Form WH-347 and covering the Work performed during the time covered by the Application. No payment will be due

and no Application for Payment processed by the Owner until all pertinent payroll documents have been completed and approved;

3. Beginning with the second Application for Payment, a current Contractor's Receipt and Partial Release in the form provided by Owner, and, if requested by Owner, similar Receipt and Partial Releases from Subcontractors and Suppliers; and

4. All information and materials required to comply with the requirements of the Contract Documents or reasonably requested by the Owner or the Professional.

D. In addition to the requirements set forth in Paragraph 14.03 C., Owner shall not be obligated to make any progress payments until the Contractor has provided Owner and Professional:

1. certificate(s) of insurance or policies as required herein;
2. a signed copy of this Contract;
3. evidence that performance and payment bonds have been purchased as required herein;
4. an approved Schedule of Values;
5. an approved construction schedule and schedule for Submittals; and
6. other documents and certifications required by the Contract Documents.

E. The Contractor warrants that title to all Work covered by an Application for Payment will pass to the Owner no later than the time of payment, free and clear of any liens, claims, security interests or encumbrances in favor of the Contractor, Subcontractors, Suppliers, or other persons or entities making a claim by reason of having provided labor, materials and equipment relating to the Work. The Contractor further expressly undertakes to defend and hold harmless the Owner, at the Contractor's sole expense, against any such claims, liens, actions, lawsuits or proceedings.

F. The Application for Payment shall constitute a representation by the Contractor to the Owner that the Work has progressed to the point indicated; the quality of the Work covered by the Application for Payment is in accordance with the Contract Documents; and the Contractor is entitled to payment in the amount requested.

14.04 Approval For Payment

A. The Professional will, within fifteen (15) days after receipt of the Contractor's Application for Payment, either approve Contractor's Application for Payment for such amount as the determines is properly due, or notify the Contractor in writing of the reasons for withholding certification in whole or in part as provided in Section 14.05.

14.05 Decisions To Withhold Approval

A. The Professional may decide not to certify payment and may withhold approval in whole or in part, to the extent reasonably necessary to protect the Owner. If the Professional is unable to approve payment in the amount of the Application, the Professional will notify the Contractor as provided in Paragraph 14.04 A. If the Contractor and Professional cannot agree on a revised amount, the Professional will promptly issue approval for payment for the amount for which the Professional is able to determine is due Contractor. The Professional may also decide not to approve payment or, because of subsequently discovered evidence or subsequent observations, may nullify the whole or a part of approval for payment previously issued, to such extent as may be necessary in the opinion to protect the Owner from loss because of:

1. defective Work not remedied or damage to completed Work;
2. failure to supply sufficient skilled workers or suitable materials;
3. third party claims filed or reasonable evidence indicating probable filing of such claims;
4. failure of the Contractor to make payments properly to Subcontractors or Suppliers for labor, materials or equipment;
5. reasonable evidence that the Work cannot be completed for the unpaid balance of the Contract Price;
6. damage to the Owner or another contractor;
7. reasonable evidence that the Work will not be completed within the Contract Times or an unsatisfactory rate of progress made by Contractor;

8. Contractor's failure to comply with applicable Laws and Regulations; or
9. failure to carry out the Work in strict accordance with the Contract Documents.

B. When the above reasons for withholding approval are removed, approval will be made for amounts previously withheld.

14.06 Progress Payments

A. Based upon Applications for Payment submitted to the Owner and Professional by the Contractor and approvals issued by the Professional, the Owner shall make progress payments on account of the Contract Price to the Contractor as provided below and elsewhere in the Contract Documents.

B. Applications for Payment shall be submitted to Owner not later than the tenth (10th) day of the month unless otherwise indicated in the Special Conditions. The period covered by each Application for Payment shall be one (1) calendar month ending on the last day of the previous month.

C. The Owner shall make payment to Contractor for amounts due and approved by Professional not later than thirty (30) days after the Owner receives a properly detailed Application for Payment which is in compliance with the Contract Documents. The Owner shall not have the obligation to process or pay such Application for Payment until it receives an Application for Payment satisfying such requirements. Payments by Contractor and all tiers of Subcontractors to all of their subcontractors and suppliers shall be made in accordance under similar terms as contained in this Paragraph 14.06 C. Contractor shall require that this term be incorporated in all tiers of subcontracts.

D. The Contractor shall promptly pay each Subcontractor and Supplier, upon receipt of payment from the Owner, out of the amount paid to the Contractor on account of such Subcontractor's or supplier's portion of the Work, the amount to which said Subcontractor or supplier is entitled, reflecting percentages actually retained from payments to the Contractor on account of each Subcontractor's or supplier's portion of the Work. The Contractor shall, by appropriate agreement with each Subcontractor or supplier, require each Subcontractor or supplier to make payments to Sub-subcontractors in similar manner.

E. Neither the Owner nor Professional shall have an obligation to pay or to see to the payment of money to a Subcontractor of any tier or a laborer or employee of Contractor except to the extent required by Laws and Regulations. Retainage provided for by the Contract Documents are to be retained and held for the sole protection of Owner, and no other person, firm or corporation shall have any claim or right whatsoever thereto.

14.07 Failure Of Payment

A. If the Owner is entitled to reimbursement or payment from the Contractor under or pursuant to the Contract Documents, such payment by Contractor shall be made promptly upon demand by the Owner. Notwithstanding anything contained in the Contract Documents to the contrary, if the Contractor fails to promptly make any payment due the Owner, or the Owner incurs any costs and expenses to cure any default of the Contractor or to correct defective Work, the Owner shall have an absolute right to offset such amount against the Contract Price and may, in the Owner's sole discretion, elect either to: (1) deduct an amount equal to that to which the Owner is entitled from any payment then or thereafter due the Contractor from the Owner, or (2) issue a written notice to the Contractor reducing the Contract Price by an amount equal to that to which the Owner is entitled.

14.08 Substantial Completion

A. Substantial Completion is the stage in the progress of the Work as defined in Paragraph 1.01 A.45. as certified by the Professional.

B. When the Contractor considers that the Work, or a portion thereof which the Owner agrees to accept separately, is substantially complete, the Contractor shall prepare and submit to the Owner and the Professional a comprehensive list of items to be completed or corrected. The Contractor shall proceed promptly to complete and correct items on the list. Failure to include an item on such list does not alter the responsibility of the Contractor to complete all Work in accordance with the Contract Documents. Upon receipt of the Contractor's list, Professional will make an inspection to determine whether the Work or designated portion thereof is substantially complete. If the Professional's inspection discloses any item, whether or not included on the Contractor's list, which is not in accordance with the requirements of the Contract Documents, the Contractor shall complete or correct such item upon notification by Professional. The Contractor shall then submit a request for another inspection by Professional to determine Substantial Completion. When the Work or designated portion thereof is substantially complete, the Professional will prepare a Certificate of Substantial Completion which shall establish the date of Substantial Completion, shall establish responsibilities of the Owner and Contractor for security, maintenance, heat, utilities, damage to the Work and insurance, and shall fix the time within which the Contractor shall finish all items on the Punch List accompanying the Certificate which shall identify all non-conforming, defective and incomplete Work. In

no event shall Contractor have more than thirty (30) days to complete all items on the Punch List and achieve Final Completion. The Certificate of Substantial Completion shall be submitted to the Owner and Contractor for their written acceptance of responsibilities assigned to them in such Certificate. Warranties required by the Contract Documents shall commence on the date of Final Completion and acceptance of the entire Work.

C. At the date of Substantial Completion, the Contractor may apply for, and if approved by Owner's Representative, the Owner, subject to the provisions herein, shall increase total payments to one hundred percent (100%) of the Contract Price less two hundred percent (200%) of the value of any incomplete Work and unsettled claims, as determined by Professional.

14.09 Partial Occupancy Or Use

A. The Owner may occupy or use any completed or partially completed portion of the Work at any stage when such portion is designated by separate agreement with the Contractor, provided such occupancy or use is consented to by the insurer and authorized by public authorities, if any, having jurisdiction over the Work. Such partial occupancy or use may commence whether or not the portion is substantially complete, provided the Owner and Contractor have accepted in writing the responsibilities assigned to each of them for payments, retainage, security, maintenance, heat, utilities, damage to the Work and insurance. When the Contractor considers a portion substantially complete, the Contractor shall prepare and submit a Punch List to the Professional and Owner as provided under Paragraph 14.09 B. Consent of the Contractor to partial occupancy or use shall not be unreasonably withheld. The stage of the progress of the Work shall be determined by Professional.

B. Immediately prior to such partial occupancy or use, the Owner, Contractor and Professional shall jointly inspect the area to be occupied or portion of the Work to be used in order to determine and record the condition of the Work. Unless otherwise agreed upon, partial occupancy or use of a portion or portions of the Work shall not constitute acceptance of Work not complying with the requirements of the Contract Documents.

14.10 Final Completion And Final Payment

A. Upon receipt of written notice that the Work is ready for final inspection and acceptance and upon receipt of a final Application for Payment, Professional will promptly make such inspection and, when Professional finds the Work acceptable under the Contract Documents and the Contract fully performed, the will promptly issue a final approval for payment; otherwise, will return Contractor's Final Application for Payment to Contractor, indicating in writing the reasons for refusing to recommend final payment, in which case Contractor shall make the necessary corrections and resubmit the Application. Submission of a Final Application for Payment shall constitute a further representation that conditions listed in Paragraph 14.10 B. as precedent to the Contractor's being entitled to final payment have been fulfilled. All warranties and guarantees required under or pursuant to the Contract Documents shall be assembled and delivered by the Contractor to the as part of the final Application for Payment. The final approval for payment will not be issued by the until all warranties and guarantees have been received and accepted by the Owner.

B. Neither final payment nor any remaining retained percentage shall become due until the Contractor submits to the Professional and the Owner (1) an affidavit that payrolls, bills for materials and equipment, and other indebtedness connected with the Work have been paid and satisfied; (2) a certificate evidencing that insurance required by the Contract Documents to remain in force after final payment is currently in effect and will not be canceled or allowed to expire until at least thirty (30) days' prior written notice has been given to the Owner; (3) a written statement that the Contractor knows of no substantial reason that the insurance will not be renewable to cover the period required by the Contract Documents; (4) consent of surety to final payment, (5) data establishing payment or satisfaction of obligations, such as receipts, releases and waivers, to the extent and in such form as may be designated by the Owner; (6) reproducible record and marked-up drawings; (7) a certification that all Punch List Work has been completed; (8) all applicable maintenance and operating instructions and warranties and guarantees have been received and accepted by Owner; (9) subject to final payment, a final release of the Owner relating to any and all claims related to the Project; (10) a certification that all operating systems and equipment have passed all tests required by the Contract Documents; and (11) all documents required by the Contract Documents and such data and other documents as Professional may reasonably require.

C. Final Payment constituting the entire unpaid balance due shall be paid by the Owner to the Contractor within thirty (30) days after Owner's receipt of Contractor's Final Application for Payment which satisfies all the requirements of the Contract Documents and Owner's receipt of all information and documents set forth in Section 14.10.

D. The acceptance by Contractor of its Final Payment shall be and operate as a release of all claims of Contractor against Owner for all things done or furnished or relating to the Work and for every act or alleged neglect of Owner arising out of the Work.

E. No payment under this Contract, including but not limited to final payment, shall constitute acceptance by Owner of any Work or act not in accordance with the requirements of the Contract Documents.

ARTICLE 15 - SUSPENSION OF WORK AND TERMINATION

15.01 Termination by Owner for Cause

A. In addition to other rights and remedies granted to Owner under the Contract Documents and by law, the Owner may terminate the Contract if the Contractor:

1. if Contractor commences a voluntary case under any chapter of the Bankruptcy code (Title 11, United States Code), as now or hereafter in effect, or if Contractor takes any equivalent or similar action by filing a petition or otherwise under any other federal or state law in effect at such time relating to bankruptcy or insolvency;
2. if a petition is filed against Contractor under any chapter of the Bankruptcy Code as now or hereafter in effect at the time of filing, or if a petition is filed seeking any such equivalent or similar relief against Contractor under any other federal or state law in effect at the time relating to bankruptcy or insolvency;
3. if Contractor makes a general assignment for the benefit of creditors;
4. if a trustee, receiver, custodian or agent of Contractor is appointed under applicable law or under contract, whose appointment or authority to take charge of property of Contractor is for the purpose of enforcing a Lien against such property or for the purpose of general administration of such property for the benefit of Contractor's creditors;
5. if Contractor admits in writing an inability to pay its debts generally as they become due;
6. refuses or fails to supply enough properly skilled workers, superintendents, foremen or managers;
7. refuses or fails to supply sufficient or proper materials;
8. fails to make payment to Subcontractors for materials or labor in accordance with the respective agreements between the Contractor and the Subcontractors;
9. breaches any warranty or representations made by the Contractor under or pursuant to the Contract Documents;
10. fails to furnish the Owner with assurances satisfactory to the Owner evidencing the Contractor's ability to complete the Work in compliance with all the requirements of the Contract Documents;
11. fails after commencement of the Work to proceed continuously with the construction and completion of the Work for more than ten (10) days, except as permitted under the Contract Documents;
12. fails to maintain a satisfactory rate of progress with the Work or fails to comply with approved construction schedules or Schedule of Submittals;
13. fails to correct defective Work.
14. if Contractor fails to perform the Work in accordance with the Contract Documents (including, but not limited to, failure to supply sufficient skilled workers or suitable materials or equipment or failure to adhere to the approved Schedule as revised from time to time);
15. if Contractor disregards Laws or Regulations of any public body having jurisdiction;
16. if Contractor disregards the authority of Professional; or
17. if Contractor otherwise violates in any substantial way any provisions of the Contract Documents;

15.02 Notice of Termination

A. Owner may, without prejudice to any other rights or remedies, after giving Contractor and the surety, seven days written notice terminate the Contract and exclude Contractor from the site and take possession of the Work and of all Contractor's tools, appliances, construction equipment and machinery at the site Contractor (without liability to Contractor for trespass or conversion), incorporate in the Work all materials and equipment stored at the site or for which Owner has paid Contractor but which are stored elsewhere, and finish the Work as Owner may deem expedient. In such case, Contractor shall not be entitled to receive any further payment until the Work is finished.

B. If the unpaid balance of the Contract Price exceeds the direct, indirect and consequential costs of completing the Work and damages, costs and expenses caused thereby (including but not limited to fees and charges of engineers, Professionals, attorneys and other professionals and court and arbitration costs) such excess will be paid to Contractor. If such costs exceed such unpaid balance, Contractor shall pay the difference to Owner. Such costs incurred by Owner will be approved as reasonable by Professional and incorporated in a Change Order, but when exercising any rights or remedies under this Article Owner shall not be required to obtain the lowest price for the Work performed.

C. In exercising the Owner's right to secure completion of the Work under any of the provisions hereof, the Owner shall have the right to exercise the Owner's sole discretion as to the manner, methods, and reasonableness of costs of completing the Work.

D. The rights of the Owner to terminate pursuant to Section 15.01 will be cumulative and not exclusive and shall be in addition to any other remedy provided by law or the Contract Documents.

15.03 Suspension by the Owner for Convenience

A. The Owner may, without cause, order the Contractor in writing to suspend, delay or interrupt the Work in whole or in part for such period of time as the Owner may determine.

B. An adjustment to the Contract Price will be made for increases in the cost of performance of the Contract caused by suspension, delay or interruption. However, in the event of a suspension under this Section 15.02, Contractor hereby waives and forfeits any claims for payment of any special, indirect, incidental or consequential damages such as lost profits, loss of savings or revenue, loss of anticipated profits, idle labor or equipment, home office overhead, and similar type damages. No adjustment will be made to the extent:

1. that performance is, was, or would have been so suspended, delayed or interrupted by another cause for which the Contractor in whole or in part is responsible, or
2. that an equitable adjustment is made or denied under another provision of this Contract.

15.04 Owner's Termination For Convenience

A. The Owner may, at any time, terminate the Contract in whole or in part for the Owner's convenience and without cause. Termination by the Owner under this Section 15.04 shall be by a notice of termination delivered to the Contractor specifying the extent of termination and the effective date.

B. Upon receipt of a notice of termination for convenience, the Contractor shall immediately, in accordance with instructions from the Owner, proceed with performance of the following duties regardless of delay in determining or adjusting amounts due under this Paragraph:

1. cease operation as specified in the notice;
2. place no further orders and enter into no further subcontracts for materials, labor, services or facilities except as necessary to complete Work not terminated;
3. terminate all subcontracts and orders to the extent they relate to the Work terminated;
4. proceed to complete the performance of Work not terminated; and
5. take actions that may be necessary, or that the Owner may direct, for the protection and preservation of the terminated Work.

C. Upon such termination, the Contractor shall recover as its sole remedy payment for Work properly performed in connection with the terminated portion of the Work prior to the effective date of termination and for items properly and timely fabricated off the Project site, delivered and stored in accordance with the Owner's instructions and for all claims, costs, losses and damages incurred in settlement of terminated contracts with Subcontractors and suppliers. The Contractor hereby waives and forfeits all other claims for payment and damages, including, without limitation, anticipated profits, consequential damages and other economic losses.

D. The Owner shall be credited for (1) payments previously made to the Contractor for the terminated portion of the Work, (2) claims which the Owner has against the Contractor under the Contract and (3) the value of the materials, supplies, equipment or other items that are to be disposed of by the Contractor that are part of the Contract Price.

E. Upon determination that termination of Contractor pursuant to Paragraph 15.01 was wrongful, such termination will be deemed converted to a termination for convenience pursuant to Paragraph 15.04, and Contractor's

sole and exclusive remedy for wrongful termination is limited to recovery of the payments permitted for termination for convenience as set forth in Paragraph 15.04.

ARTICLE 16 – DISPUTE RESOLUTION

16.01 Methods and Procedures

A. All Claims, disputes, and other matters in question between the Contractor and the Owner arising out of or relating to this Agreement or breach thereof shall be subject to and decided by arbitration in accordance with the Construction Industry Arbitration Rules of the American Arbitration Association currently in effect unless the parties mutually agree otherwise. At the Owner's sole option, and only upon the exercise of that sole option by the Owner, together or separately as the Owner sees fit, any dispute or other matter in question as described above may be submitted, prior to any arbitration, to nonbinding mediation in accordance with the then-current mediation rules of the American Arbitration Association. The mediation may include by consolidation, joinder or in any other manner, at the Owner's sole option, any other persons whom the Owner believes to be substantially involved in a common question of fact or law.

B. Any arbitration arising out of or relating to this Agreement or the breach thereof may include, by consolidation, joinder, or in any other manner, at the Owner's sole option, any other entities or persons whom the Owner believes to be substantially involved in a common question of fact or law.

C. A demand for arbitration shall be provided in writing to the other party to this Agreement and filed with the American Arbitration Association. A demand for arbitration shall be made within a reasonable time after the claim, dispute, or other matter in question has arisen. In no event shall the demand for arbitration be made after the date when institution of legal or equitable proceedings based on such claim, dispute, or other matter in question would be barred by the applicable statutes of limitations. If the Owner shall elect to proceed with nonbinding mediation, such election shall be made, in writing, to the Contractor and the American Arbitration Association. Such election may be made before or after either party files any demand for arbitration, but the Owner's unilateral right to proceed with mediation shall be forfeited upon the final designation of an arbitrator by the American Arbitration Association. The election to proceed with nonbinding mediation shall not prejudice the right of either party to proceed with arbitration.

D. Unless the parties agree otherwise, discovery as provided by the Federal Rules of Civil Procedure shall be allowed in the arbitration, provided, that the arbitrator(s) shall have the authority to restrict unduly burdensome and onerous discovery. The parties shall exchange documents the parties intend to use at the hearing and disclose witnesses they anticipate testifying at the hearing. If a party intends to use an expert, such party shall provide the other party an expert report disclosing the expert's opinions and the reasons for the opinion.

E. The place of the arbitration shall be Grain Valley, Missouri.

F. This agreement to arbitrate shall be specifically enforceable under the prevailing arbitration law. Any award rendered by the arbitrator(s) shall be final and enforceable by any party to the arbitration, and judgment may be rendered upon it in accordance with applicable law in any court having jurisdiction thereof.

16.02 Continuing Performance

A. Unless otherwise agreed in writing, and notwithstanding any other rights or obligations of either of the parties under this Agreement, the Contractor shall carry on with the performance of its Services hereunder during the pendency of any claim, dispute, or other matter in question or arbitration or other proceeding to resolve any claim, dispute, or other matter in question, and the Owner shall continue to make payments of undisputed amounts to the Contractor in accordance with this Agreement, but the Owner shall be under no obligation to make payments to the Contractor on or against such claims, disputes, or other matters in question, during the pendency of any arbitration, nonbinding mediation, or other proceeding to resolve such claims, disputes, or other matters in question.

16.03 Exceptions

A. Regardless of any term or provision herein to the contrary, claims arising out of actions on claims filed or asserted by third parties on account of personal injury or death of any person shall not be subject to the terms and provisions of this Article 16.

ARTICLE 17 - MISCELLANEOUS

17.01 Notice

All notices required to be given under the terms of this Contract shall be made in writing and shall be deemed to have been made and given if sent by registered or certified mail, postage prepaid or hand-delivered (hand delivery to include by air courier services such as Federal Express, Airborne Express, or Purolator or other reputable delivery service

guaranteeing delivery and providing a receipt) to the party to receive such notice at the addresses specified below or to such other address as any party hereto may subsequently specify by written notice to the other party:

If to Owner: Person and address contained in the Agreement

If to Contractor: Address contained in the Agreement or the temporary office of Contractor at the Site.

17.02 Rights and Remedies

A. Duties and obligations imposed by the Contract Documents and rights and remedies available thereunder shall be in addition to and not a limitation of duties, obligations, rights, and remedies otherwise imposed or available by law. No action or failure to act by the Owner or Professional will constitute a waiver of a right or duty afforded to Owner under the Contract Documents, nor will such action or failure to act constitute approval of or acquiescence in a breach thereunder, except as may be specifically agreed in writing. The terms of this Contract and all representations, indemnifications, warranties and guarantees made in, required by or given in accordance with the Contract Documents, as well as all continuing obligations indicated in the Contract Documents, will survive final payment, completion and acceptance of the Work and termination or completion of the Work and shall remain in effect so long as the Owner is entitled to protection of its rights under applicable law. Contractor shall carry out the Work and adhere to the current construction schedule during all disputes or disagreements with the Owner. No Work shall be delayed or postponed pending resolution of any disputes or disagreements except as the Owner and Contractor may otherwise agree to in writing.

17.03 Buy American Requirements

A. Pursuant to the Missouri Domestic Product Procurement (Buy American) Act, RSMo. §§ 34.350 to 34.359, any manufactured goods or commodities used or supplied either in the performance of this Contract or of any subcontract thereto shall be manufactured, assembled or produced in the United States unless one of the exceptions contained in that Act applies. The Contractor shall comply with such requirements and shall provide proof of compliance with this provision both at the time of bid and before any payment is made on the Contract. Pursuant to RSMo. § 71.140, preference shall be given to materials, products, supplies, provisions and all other articles produced, manufactured, compounded, made, or grown in the State of Missouri. The Contractor shall comply with such requirements and shall provide proof of compliance with this provision at the time of bid and before any payment is made on the Contract.

17.04 Successors and Assigns

A. The Contractor hereby binds itself, its partners, successors, assigns and legal representatives to the Owner in respect to covenants, agreements and obligations contained in the Contract Documents. Contractor shall not assign the Contract or proceeds hereof without written consent of the Owner. If Contractor attempts to make such an assignment without such consent, it shall be void and confer no rights on third parties, and Contractor shall nevertheless remain legally responsible for all obligations under the Contract. The Owner's consent to any assignment is conditioned upon Contractor entering into a written assignment which contains the following language: "it is agreed that the funds to be paid to the assignee under this assignment are subject to performance by the Contractor and to claims and to liens for services rendered or materials supplied for the performance of the Work required in said Contract in favor of all persons, firms, corporations rendering such services or supplying such materials."

17.05 Records

A. The Owner, or any parties it deems necessary, shall have access to and the right to examine any accounting or other records of the Contractor involving transactions and Work related to this Contract for five (5) years after final payment or five (5) years after the final resolution of any on going disputes at the time of final payment. All records shall be maintained in accordance with generally accepted accounting procedures, consistently applied. Subcontractors of any tier shall be required by Contractor to maintain records and to permit audits as required of Contractor herein.

17.06 General

A. The Contract Documents are the exclusive statement of the agreement of the parties with respect to its subject matter and the Contract Documents supersedes and replaces all prior agreements, discussions and representations, whether written or oral, relating to the subject matter hereof. The Contract Documents may only be amended, modified or changed by a Modification.

B. All headings, titles and paragraph captions are inserted in this Contract for convenience of reference only, are descriptive only and shall not be deemed to add or detract from or otherwise modify the meaning of the paragraphs.

C. Contractor acknowledges and agrees that time and exact performance are of the essence of this Contract.

D. Contractor and Owner agree to do all acts and things and to make, execute and deliver such written instruments, as shall from time to time be reasonably required to carry out the terms and provisions of the Contract Documents.

E. Any specific requirement in this Contract that the responsibilities or obligations of the Contractor also apply to a Subcontractor is added for emphasis and are also hereby deemed to include a Subcontractor of any tier. The omission of a reference to a Subcontractor in connection with any of the Contractor's responsibilities or obligations shall not be construed to diminish, abrogate or limit any responsibilities or obligations of a Subcontractor of any tier under the Contract Documents or the applicable subcontract.

F. This Contract shall be interpreted, construed, enforced and regulated under and by the laws of the State of Missouri. Whenever possible, each provision of this Contract shall be interpreted in a manner as to be effective and valid under applicable law. If, however, any provision of this Contract, or a portion thereof, is prohibited by law or found invalid under any law, only such provision or portion thereof shall be ineffective, without invalidating or affecting the remaining provisions of this Contract or valid portions of such provision, which are hereby deemed severable. Contractor and Owner further agree that in the event any provision of this Contract, or a portion thereof, is prohibited by law or found invalid under any law, this Contract shall be reformed to replace such prohibited or invalid provision or portion thereof with a valid and enforceable provision which comes as close as possible to expressing the intention of the prohibited or invalid provision.

G. Each and every provision of law and clause required by law to be inserted in this Contract shall be deemed to be inserted herein, and the Contract shall be read and enforced as though it were included herein, and if through mistake or otherwise any such provision is not inserted, or is not correctly inserted, then upon the written application of either party the Contract shall forthwith be physically amended to make such insertion or correction.

H. Owner's total liability to Contractor and anyone claiming by, through, or under Contractor for any Claim, cost, loss, expense or damage caused in part by the fault of Owner and in part by the fault of Contractor or any other entity or individual shall not exceed the percentage share that Owner's fault bears to the total fault of Owner, Contractor and all other entities and individuals as determined on the basis of comparative fault principles.

I. Contractor agrees that Owner shall not be liable to Contractor for any special, indirect, incidental, or consequential damage whatsoever, whether caused by Owner's negligence, fault, errors or omissions, strict liability, breach of contract, breach of warranty or other cause or causes whatsoever. Such special, indirect, incidental or consequential damages include, but are not limited to loss of profits, loss of savings or revenue, loss of anticipated profits, labor inefficiencies, idle equipment, home office overhead, and similar types of damages.

J. Nothing contained in this Contract or the Contract Documents shall create any contractual relationship with or cause of action in favor of a third party against the Owner.

K. Any provision or provisions of this Contract to the contrary notwithstanding, Contractor and Owner intend that the relationship between Owner and Contractor shall be that of a project owner and an independent contractor.

L. Payments and amounts due and unpaid by Contractor to Owner under the Contract Documents shall bear interest from the date payment is due at the rate of one and one-half percent (1.5%) per month.

M. The terms "hereof," "herein," and "hereunder" and words of similar import shall be construed to refer to this Contract as a whole, and not to any particular paragraph, section or provision unless expressly so stated.

N. Should Owner be required to institute any action, including, any arbitration proceeding, to enforce any of its rights set forth in the Contract Documents, then Owner shall be entitled to reimbursement from Contractor for all reasonable attorneys' fees and costs incurred. In the event Contractor institutes any action, including any arbitration proceeding, against Owner and in the further event Owner prevails in such action, Contractor shall pay Owner the amount of its reasonable attorneys' fees incurred in such action.



LIFE OUTSIDE THE LINES

**PROJECT SPECIAL CONDITIONS OF
THE CONSTRUCTION CONTRACT**

City of Grain Valley, MO

711 S. Main Street

Grain Valley, MO 64029

Phone: (816) 847-6200

Fax: (816) 847-6209

PROJECT SPECIAL CONDITIONS

SC-01 Scope of Work

The work provided for in these specifications shall consist of furnishing all labor, materials. Equipment and other services necessary to construct the 2024 Concrete Replacement and Paving Program as described herein. Work shall include but not be limited to removing existing concrete, installing new concrete, resident notifications, on-site traffic control, and all other incidental and related work as shown in the contract documents and as described herein. Mobilization will not be paid as a separate pay item and shall be included in the prices for other bid items.

SC-02 Execution of Contract Documents

Five (5) copies of the Contract Documents will be prepared by the Owner for execution by the Contractor. All copies of the Contract shall be executed by the Contractor and the Contractor shall insert executed copies of all of the required bonds, Certificate of Liability Insurances and Power of Attorney and submit all copies to the Owner. The date of the contract agreement and bond forms shall be left blank for filling in by the Owner. The City will return 2 copies to the contractor.

SC-03 Scope, Nature and Intent of Specifications and Plans

The work shall also conform to the following referenced standards which are hereby incorporated into the Contract Documents:

1. "Standard Specifications and Design Criteria", Current Edition as published by the Kansas City Metropolitan Chapter of the American Public Works Association (APWA)
2. The City of Grain Valley Standard Detail Drawings as revised September 2022.

SC-04 Before Starting Construction

Prior to the start of construction, the Contractor shall submit for approval of the Owner all required shop drawings, mix designs, traffic control details and the proposed project schedule.

SC-05 Sub-Contracting

Section 6.09G is hereby amended to read "Contractor shall perform with its own forces and organization Work amounting to no less than sixty percent (60%) of the original contract price.

SC-06 Assignment and Subletting of Contract

No second tier subcontracting will be permitted. It shall be the responsibility of the Contractor to ensure that his/her subcontractors do not in turn subcontract any portion of the work. Assigning, transferring or subletting, even though consented to, shall not relieve the Contractor of his liabilities under this contract. The Contractor shall give his personal attention to any and all portions of the contract which has been sublet and he shall be responsible for its proper construction.

SC-07 Partial Occupancy or Use

Section 14.09 of the General Conditions is hereby modified to allow completed work to be occupied by the Owner without acceptance in writing. Occupancy does not waive any rights of the Owner, or of any power herein reserved for the Owner, or any damages herein provided, nor shall it relieve the Contractor of any obligations provided herein.

SC-08 Maintenance of Traffic

The Contractor shall conduct his work so as to interfere as little as possible with public travel, vehicular or pedestrian. In no case shall a road be completely closed. Flagging and traffic control shall be in accordance with the contract documents and the MUTCD. It shall be the Contractor's responsibility to check the traffic control devices each evening to make sure they are in place before leaving the jobsite. At least one lane of traffic must be maintained at all times unless approved by the Owner. Any approved road closures shall be properly signed by the Contractor after the closure and signing plan has been approved by the Owner. The contractor shall place signage warning motorist of gravel and oil. See Appendix for Typical Construction Signing.

SC-09 Responsibility of Contractor

In addition to the responsibilities outlined in Article 6 of the General Conditions, the Contractor shall also be responsible for:

1. Taking necessary precautions to keep loose aggregate, mud, excess concrete and other debris being deposited onto open lanes of the existing, or offsite paving during construction operations. Should aggregate, mud, excess concrete or debris become deposited upon such open lanes of existing pavement, the Contractor shall promptly remove it at no additional cost to the Owner.
2. Before the work will be accepted by the Owner, the Contractor shall be required to remove all aggregate, mud, excess concrete and other debris resulting from his operation, which also includes cleaning of streets, ditches, creeks and driveways of objectionable materials within the project limits.

SC-09 Inspection

This project will be inspected by City of Grain Valley personnel and will use MoDOT standard inspections protocol. Contractor shall notify his subcontractors, Owner and all other contractors when he is ready for them to install their portions of the work. Contractor shall not put in place any work which will prevent observation and approval of previous work without first notifying the Owner. Contractor shall provide the Owner with delivery tickets for all Asphaltic Concrete delivered for placement prior to placement of the Asphaltic Concrete.

SC-10 No Waiver of Right

Neither the inspection or evaluation by the Owner or any of the Owner's officials, employees, or agents, nor any order by the Owner for payment of money, nor any payment for, or acceptance of, the whole or any part of the work by the Owner, nor any extension of time, nor any possession taken by the Owner or its employees shall operate as a waiver of any provision of this contract, or of any power reserved to the Owner, or any right to damages herein provided, or shall any waiver of any breach in this contract be held to be a waiver of any other or subsequent breach.

SC-011 Beginning, Progress and Time of Completion of Work

The time for completion of the work is an essential part of the Contract. It shall begin on the date stated in the Notice To Proceed and shall be the number of calendar days as stated in the Proposal and as follows:

Contractor shall not be allowed to work on Saturdays, Sundays or Holidays without prior approval by the City. Contractor will need to coordinate with the Owner on the after hours and weekend schedules. Normal workweek hours are 7:30 am to 4:30 pm.

The Contractor shall take, at no additional expense to the Owner, whatever means are necessary including but not limited to working nights, weekends, double shifts, temporary weather enclosures to assure substantial completion of all work during the Contract Time.

Prior to starting work, a pre-construction conference will be held to discuss the project, scheduling and its coordination with the work of others. It is expected that this conference will be attended by the Owner, the Contractor, his subcontractors and other contractors of the Owner as needed.

SC-12 Schedule

The Owner is presently planning to engage a contractor to perform an asphalt overlay program. Some of the work planned herein requires completion prior to the asphalt overlay. The City is currently planning to issue a Notice To Proceed in April 2024 with completion by June 30, 2024.

SC-13 Compliance With Laws

1. The Contractor shall comply with all Federal, State and Local Laws and Ordinances.
2. Contractor and each subcontractor shall require each on-site employee to complete the ten-hour safety program required under Section 292.675 RSMo, with 60 days of beginning any work on the project, if he or she has not previously completed the program or does not have documentation of having done so, the contractor shall forfeit a penalty to the City of \$2,500 plus \$150 for each on-site employee employed by Contractor or subcontractor, for each calendar day, or portion thereof, such employee is employed without the required documentation.

SC-14 Force Account

1. This work shall cover miscellaneous extra work required during the course of construction.
2. Before the extra work is performed, the contractor shall submit a proposed price in accordance with the Contract requirements for approval by the Owner and shall have received the written approval of the Owner, prior to commencing the proposed extra work.



LIFE OUTSIDE THE LINES

TECHNICAL SPECIFICATIONS

SECTION 03100 – CONCRETE FORM WORK

PART 1 - GENERAL

1.01 SECTION INCLUDES

- A. Forming all cast-in-place concrete as required by the work and form removal.
- B. Forming accessories.

1.02 RELATED SECTIONS

- A. Section 02200: Excavation, Backfill, and Site Grading
- B. Section 03200: Concrete Reinforcement
- C. Section 03300: Cast-in-place Concrete

1.03 SUPERVISION

- A. Provide qualified supervision on the job at all time form erection or removal is in progress.
- B. All persons erecting forms shall be journeyman carpenters.

1.04 PRODUCT HANDLING

- A. Protection:
Form material to be used on the project shall be stored in a neat manner, off the ground and protected from weather when not in use.
- B. Design:
Form structure shall be designed according to American Plywood Association published data for plywood forms.
- C. Replacement and repair:
Forms damaged during use shall be repaired before storing. Damaged material shall be removed from the site.

PART 2 - MATERIALS

2.01 MATERIALS

- A. Form lumber:
All lumber to be used in forming structural concrete shall be new except as allowed for reuse as described in Part 3.
 - 1. Class 1B-B exterior type plyform. Medium density overlaid with sealed edges required for concrete exposed to view on project completion.
 - 2. "Steel Ply" as manufactured by Symons Corporation with plastic overlaid plywood panels.
 - 3. Equal system approved for this project.

2.02 TIES AND SPREADERS

- A. Form ties for non-exposed concrete walls shall be Richmond standard SBR "Snap-Ty" with 1-inch break back as manufactured by Richmond Screw Anchor Co., Inc.

- B. Form ties for concrete walls exposed to view or walls exposed to water shall be SPC Snap-Ty with 1-½ inch plastic cone.
- C. Spreaders shall be ST FC or ST FC-N steel spreaders as manufactured by Richmond Screw Anchor Company, Inc.
- D. Miscellaneous forming accessories required for the work shall be similar and equal to those manufactured by Richmond.
- E. Products of other manufacturer but equal to the above will be considered, and are subject to the Engineer's approval.

PART 3 – EXECUTION

3.01 GENERAL

All concrete work shall be formed using fabricated forms as specified in this Section. Earth forming will be permitted only where fence post or thrust block requires direct bearing against undisturbed earth.

3.02 COORDINATION

- A. Other trades:
The Contractor shall coordinate the work of all other trades and subcontractors before undertaking concrete formwork.
- B. Conflicts:
The Contractor shall notify the Engineer in the event there is conflict between plan requirements for forming and other construction requirements.

3.03 ERECTION OF FORMS

- A. General:
Forms shall be erected true and rigid with adequate bracing to ensure permanent alignment.
- B. Cleaning:
Provide cleanout openings at bottom of all wall forms to permit cleaning after erection.
- C. Alignment:
 - 1. Joints between form panels shall be adjusted and accurately anchored to prevent offsets in concrete surfaces and leakage of concrete during placement.
 - 2. Bowed forms will not be accepted.
- D. Embedded items:
Set all anchor bolts, shear keys, pipe hanger supports, blockouts, sleeves, and other items required for subsequent construction and equipment or material of other trades.
- E. Keyways:
Keyways shall be formed from 2 by lumber, cut to size and shape called for. Keyway

forms shall be secured in place before placement of concrete. Forming keyway after concrete is placed will not be allowed.

- F. Tolerance:
Dimensional tolerances shall not exceed the following:
1. Floors and slabs:
Plus or minus 1/4 inch. Floor shall not pond water.
 2. Building alignment:
Not to exceed 1/2 inch.
 3. Structural member alignment. Not to exceed 1/480 span.
 4. Width of structural member or wall:
Not to exceed 1/5 inch.
 5. Basin:
Plus 1/2 inch minus 0 for all horizontal dimensions.
 6. Walls:
Elevation differential of top of walls and overflows shall be plus or minus 1/8 inch not to exceed 1/4 inch in 20 feet horizontally.
 7. Wall depth:
Plus 1 inch minus 0.

3.04 FORM RE-USE

- A. General:
Forms may be reused so long as they are in good condition, will form a continuous plane surface, have square corners and will form mortar tight joints.
- B. Metal forms:
Metal forms with plywood panels must meet the above criteria and must lock to a rigid position to prevent movement between adjacent forms.

3.05 FORM REMOVAL

- A. General:
1. Forms shall be removed in a careful workman manner. Precautions shall be taken to prevent danger or hazard to workmen or other persons.
 2. Form removal shall be performed in a manner to protect the formed concrete and other construction from damage.
- B. Clean-up:
1. Forms shall be cleaned immediately and neatly stored if re-use is intended. Cleaning shall include repair and oiling.
 2. Damaged form material shall be promptly removed from the site.
- C. Concrete repair:
Any repair of newly formed concrete that is required by Section 03300 shall be made immediately after forms are removed.

END OF SECTION

SECTION 03200 – CONCRETE REINFORCEMENT

PART 1 - GENERAL

1.01 SECTION INCLUDES

- A. Reinforcing steel and related items required for cast-in-place concrete

1.02 RELATED SECTIONS

- A. Section 03100: Concrete Form Work
- B. Section 03300: Cast-In-Place Concrete

1.03 SUPERVISION

- A. Workmanship:
Provide qualified supervision at all times reinforcing work is in progress. Workmen shall be experienced ironworkers.
- B. Codes:
Reinforcement placement and detailing shall comply with practice specified in the "Manual of Standard Practice for Detailing Reinforced Concrete Structures" publication ACI 315-80 of the American Concrete Institute or its latest revision, unless otherwise specified herein.

1.04 SUBMITTALS

- A. Shop drawings:
Shop drawings shall be prepared for all reinforcement required by the project. Shop drawings shall be logically and legibly prepared to permit reasonable ease of sorting, selecting, placing reinforcement as well as checking drawings. Preparer and fabricator shall be identified on the drawings.
- B. Fabrication:
Reinforcement shall not be fabricated until shop drawings have been processed, approved, and returned.

1.05 PRODUCT HANDLING

- A. Protection:
 - 1. Use all means necessary to protect reinforcement from dirt and other foreign substances before and after placing.
 - 2. Store in a neat manner in logical order, bundled, tagged, off the ground, and in an area adequately isolated.
 - 3. Re-bundle to maintain identification when placing is interrupted.
- B. Replacement:
All damaged or improperly fabricated bars shall be replaced at the Contractor's expense.

PART 2 – MATERIALS

2.01 CONCRETE REINFORCEMENT

- A. General:
All reinforcement shall be free from rust, loose mill scale, and other contaminants.
- B. All bars shall be billet steel bars for concrete reinforcement ASTM A615 Grade 60. All reinforcements shall be epoxy coated.
- C. Welded steel wire:
Welded steel wire shall meet ASTM A185.
- D. Accessories:
 - 1. General:
Accessories shall be subject to Engineer's approval.
 - 2. Tie wire – 18-gauge steel wire.
 - 3. Support above form with fabricated steel chairs. Number of chairs shall be adequate to prevent sag during steel and concrete placement.
 - 4. Support above subgrade with solid concrete bricks.
 - 5. Wall layer spacers shall be ¼-inch round "Z" bar.
 - 6. Horizontal layer spacers shall be Standee.
- E. Dowel bar splicer:
 - 1. Dowel bar splicer shall be Richmond or approved equal, manufactured from standard specified rebar material, with NC threads and shop fabricated to specified dowel configurations.

PART 3 - EXECUTION

3.01 GENERAL

- A. Other trades:
Coordinate all work of other trades to avoid conflict with reinforcement.
- B. Shop drawings:
Check all shop drawings to verify dimensions required.

3.02 FABRICATING

- A. General:
Reinforcement shall be shop fabricated except where straight bars No. 5 or smaller are required.
- B. Bending:
All bending shall be by using bending jigs and mandrels. All bars shall be bent cold.
- C. Cutting:
Bars shall be cut by cold shearing. Torch cutting in the field may be permitted in special situations.

3.03 PLACING

- A. General:
 - 1. Accurately place all bars and tie in place before placing concrete, include dowels. Tie at all intersections with 18-gauge steel wire.
 - 2. Corner bars required for horizontal reinforcing. Unless otherwise noted on plans corner bars shall be same size as horizontal bar.
- B. Clearance:
 - 1. Preserve clearance between bars of 1 inch minimum, not less than one bar diameter or 1-1/3 times large aggregate, whichever is larger.
 - 2. Provide following concrete coverage over reinforcing steel unless otherwise indicated on plans:
 - a. Three inches above subgrade - in excavation.
 - b. Two inches above subgrade - slab on fill.
 - c. Two inches from form - walls exposed to water or earth.
 - d. One and one-half inches from form - normal cover interior walls, beams, columns, etc.
 - e. One and one-half inch on top steel - interior slabs.
 - f. One and one-half inches on top and bottom - exterior slab or slab over or under water.
- C. Splicing:
 - 1. Lap all reinforcing bars as required by ACI 318-77 Class B lap with a minimum of 36 diameters except where otherwise shown or required by ACI.
 - 2. Stagger splices except where otherwise shown.
 - 3. Lap welded wire two spaces.
- D. Dowels:

All dowels shall be placed and securely anchored before placing concrete.
- E. Supports:
 - 1. Secure all reinforcement in place using steel chairs, supports, Z bars and other products fabricated for the purpose. Supports shall be spaced adequately to support the steel firmly in place. Use sand plates or other approved products when reinforcement is placed on sand or earth subgrade.
 - 2. Chairs will not be accepted to hold reinforcing clearance on walls.
- F. Openings and obstructions:
 - 1. Place one extra No. 5 bar, 4 feet long, diagonally in each face at corners of openings. Place No. 4 hoop around all round openings.
 - 2. Bend reinforcing around obstructions. Place extra reinforcing where cutting is authorized. Engineer's approval required before cutting steel.
 - 3. Consult Engineer on special situations.

CONCRETE REINFORCEMENT

- G. Certification:
Certify material and type of deformation.
- H. Condition:
All reinforcement shall be free from loose rust, dirt coating, oil, paint, or any foreign substance.

END OF SECTION

SECTION 03300 – CONCRETE

PART 1 - GENERAL

1.01 SECTION INCLUDES

This specification covers all cast-in-place plain and reinforced concrete construction required by the plans and specifications in the performance of this Contract, including all materials, labor, equipment and appliances.

PART 2 – MATERIALS

2.01 MATERIALS

Materials shall conform to the requirements of the Kansas City Metropolitan Materials Board (KCMMB).

- A. Cement. Cementitious materials shall meet the requirements of the KCMMB.
- B. Fine Aggregate. Aggregate for concrete shall meet the requirements of the KCMMB.
- C. Coarse Aggregate. Aggregate for concrete shall meet the requirements of the KCMMB.
- D. Mixing water. Mixing water for concrete shall be potable and shall meet the requirements of the KCMMB.
- E. Air-Entraining Agent. Air-entraining agents used to produce specified amounts of air entrainment shall meet the requirements of the KCMMB.
- F. Admixtures - Admixtures listed in the KCMMB mix design as “optional” will be used only with prior approval of the engineer.
- G. Reinforcing Steel.
 - 1. General: All reinforcing steel shall be deformed bars and shall comply with ASTM Designation A615, Grade 40 or 60.
 - 2. Bar Supports: All bolsters and chairs shall be in accordance with ACI Standard 513, and those used in the underside of the top slabs shall be pre-galvanized. On sub-grade, support on continuous chairs.
 - 3. Fabrication: Fabrication of reinforcing steel shall be in accordance with ACI Standard 315. Requirements for laps, spacing, edge distance, length and bending of bars are given on the Plans. Reinforcing steel shall be protected from damage at all times. The bars shall be firmly tied at the alternate crossings, or closer. The steel shall be tied in correct position, positively secured against displacement, and inspected before any concrete is placed. Care shall be exercised to maintain proper clearance between the forms and the reinforcement. Bars at the top of lifts shall be held securely in correct position by means of approved metal bar supports. Before any concrete is placed, any dried mortar, loose rust or mud shall be cleaned from the reinforcing steel.

- H. Welded Wire Fabric: ASTM Designation A-185.
- I. Expansion Joint Filler: AASHTO M213.

2.02 READY MIXED CONCRETE

- A. Ready mixed concrete, in accordance with ASTM Designation C-94, shall be used unless otherwise authorized by the Engineer. Any concrete which is not plastic and workable when placed on the subgrade or in the forms shall be rejected.
- B. Concrete shall be completely placed and consolidated in the forms in accordance with 3.02B of this Section.

2.03 CONCRETE MIX

- A. KCMMB 4K Concrete Construction: All concrete used in construction of curb and gutters, retaining walls, culvert aprons, inlets, junction boxes, yard inlets, manholes, ditch liners, sidewalks, and integral sidewalk retaining walls shall be classified as Class KCMMB 4K unless otherwise stated in the plans.

PART 3 – EXECUTION

3.01 CURING CONCRETE

Maintain continuously for 5 days after placing:

- A. Concrete temperature at least 50° F. and not over 100° F.
- B. Concrete Moisture:
 - 1. Walls & Structures: Cover with 6 mil polyethylene film and leave forms on 5 days, except as required for rubbing.
 - 2. Slabs: Polyethylene membrane 4 mil thick; lap joints 6". Hold down with 1 x 4 at laps and at 6 foot centers. Membrane to be translucent or white in hot weather; black in cold weather.
 - 3. Pavement, Walks, Channels, and other Approved Structures: Spray approved membrane -One (1) gallon to 200 square feet.

3.02 SPECIAL WEATHER CONDITIONS

- A. Cold Weather. The Contractor shall comply fully with the provisions of ACI 306.1-90 as modified below:
 - 1. Average daily temperatures as defined in ACI 306.1-90 will be determined and recorded by the City.
 - 2. Concrete temperatures will be determined through the use of high-low thermometers placed and operated by the contractor below insulated blankets, or where the concrete is uncovered, by checking air temperatures. Uncovered concrete, which has been subjected to freezing temperatures of any duration during the first 24 hours will be considered "frozen," and shall be rejected.
 - 3. The months of December, January and February will be considered "Cold

- Weather” and will require concrete protection, regardless of temperature.
4. Concrete shall reach 75% of its design strength prior to backfilling. This strength can be determined through the use of field-cured cylinders, made and tested at contractor’s expense. Concrete must have 5 days where the average daily temperature is above 50 degrees F prior to backfilling unless field cured cylinders are taken. These days do not need to be consecutive.
 5. All coverings and heating equipment shall be on hand prior to beginning placement of the concrete.

B. Hot Weather. Concrete operations in hot weather shall conform to the following requirements:

1. Place concrete within the time and temperature conditions shown in Table below.

Ambient Air Temperature and Agitated Concrete Placement Time		
T=Ambient Air Temperature at Time of Batching (°F)	Specimen Age Time limited agitated concrete must be placed within, after addition of cement to water (hours)	Admixtures
T<75	1 ½	None
75≤	1	None
75≤T<90	1 ½	Set Retarder

2. In all cases, if the concrete temperature at time of placement is 90°F or above, or under conditions contributing to quick stiffening of the concrete, place the concrete within 45 minutes of adding the cement to the water. Do not use concrete that has developed its initial set. Regardless of the speed of delivery ad placement, the Engineer will suspend the concreting operations until corrective measures are taken if there is evidence that the concrete cannot be adequately consolidated.

3.03 FORMS - WALL

- A. Forms shall be constructed from surface finished plywood and 2 x 4 studs or approved manufactured forming system. All form material shall be in first class condition and with mortar tight joints. Provide cleanouts at bottom and remove debris.
- B. Forms shall be erected true and rigid with adequate bracing to insure alignment. Provide chamfer for all exposed corners.

3.04 CONCRETE FINISH

- A. All concrete shall be finished monolithically. No "topping" or "plastering". Walls exposed to view shall be rubbed to produce uniform sandy texture without air voids, fins, form marks or offsets. Tops of all walls shall be hard trowel finish with

chamfered corners.

- B. Pavement slab, slope paving, inlet tops, sidewalk, and exposed slabs of structures shall receive a light broom finish.

3.05 JOINTS

- A. Joints shall be constructed as shown on the Plans. Unless shown on the plans, joints shall not be constructed unless approved by the Engineer.
- B. All construction joints shall be made with canted 2 x 4 at least 2 inches from wall face. All construction joint contact surfaces shall be finished with wood float finish.
- C. Normal Grout
Furnish and install normal cement grout where called for on the plans. Mix to be one part sand to 2 parts cement by volume. Use minimum water required for workability.
- D. Expanding Grout
Proportion by weight 1 part normal Portland cement, 1 part sand and 1 part Ironite compound similar and equal to Embecco (Master Builders Co.). Thoroughly dry mix and add a minimum of water to a stiff consistency as limited by placing conditions. Firmly pack mortar into the hole or joint and moist cure for three days.

3.07 CONCRETE EQUIPMENT AND PLACING

- A. The Contractor's attention is called to the size of concrete pours required. He shall have sufficient crews, vibrators and other equipment to properly handle same so that no cold joints will be created and that concrete surfaces will be kept "alive". The Engineer shall be advised in advance of the equipment to be used.
- B. Before delivery of concrete the Contractor shall have made all necessary preparations and shall have all necessary items on hand not only for proper placing but for covering, curing, heating, finishing, rubbing and/or as required to perform in accordance with the Plans and Specifications. Failure to be properly prepared may result in inability to perform properly and consequent rejection of the work.
- C. Any concrete damaged by the Contractor's equipment, or by other means during construction shall be replaced at the Contractor's expense.

END OF SECTION



LIFE OUTSIDE THE LINES

APPENDIX

CONCRETE REPLACEMENT AND PAVING

City of Grain Valley, MO

711 S. Main Street

Grain Valley, MO 64029

Phone: (816) 847-6200

Fax: (816) 847-6209

Location	CG-2 Curb Replacement Units	CG-2 Curb Replacement Linear Feet	New 4" Sidewalk Square Feet	4" Sidewalk Replacement Square Feet	ADA Ramp Square Feet	Detectible Warning Square Feet	6" Reinforced Slab Square Feet	Replace 6" Drive Approach Square Feet
Abar		7	340		25	8		
Aspen Court		7	11		25	8		
Azalea Circle		14			50	8		
Boxwood at Elmwood Drive				64	50	16		
Bradford Court			56					
Cedar Lane		7	20	20	25	8		
Cottonwood Dr at Woodbury Dr				64	70	20		
Country Hill				32				
Cross Creek Dr North		21	615		85	28		
Cross Creek Dr South		73	504		50	16		
Cross Creek Lane		181			80	30		
Dean Drive		90						
Eagle Ridge Parkway		14	520		50	25		
Foxtail Drive		30						
Foothill Drive		146		120	100	32		
Garden Street		7	192		25	8		
Gateway Drive		10	560		60	20		
Graystone Drive		30						
Hedgewood Drive		67			50	16		
Hickory Ridge		14	364		50	16		
High View Drive		7	80		25	8		
Hillside Court		80		96				
Indian Creek Drive		35						
Lakeview Drive		85	252	32	25	8		
Lone Star Ct at Montana Ridge		140						
Long Drive		203			250	80		
Magnolia Drive		14			50	16		
Meadow Court		21	640		80	30		308
Meadow Drive		21	752	40	80	12		
Meadowood Drive		53	692		25	8		544
Montana Ridge		45		16				
Nelson Drive		150						
Nolan Drive		7	196		25	8		
Oakwood Lane		154		40	50	16		
Pamela Drive		10	108		30	10		
Pebblebrook Drive		15						
Phelps Drive			528					
Phelps Court			456					
Pond Avenue		7	64		25	8		
Red Bud Drive				64				
Ridgeview Drive		126			100	32		
Rockcreek Lane (off Buckner Tar:		30		200			200	
Rockcreek Lane (Cross Creek Subd)			504					
Rosewood Drive		182		80	275	88		
Royer Drive		94	2608		30	10	200	
Sawgrass Drive		77		32	25	8		
Silverstone Circle		14			50	8		
Silverstone Court		14			50	8		
Sni-A-Bar Blvd @ Eagles Pkwy		10	272		30	10		
Sni-A-Bar Parkway			920					
Squire Court		155						
W Walnut Street		30			100	32		
Willow Drive		60		48				
Whitney Drive		10	192	48	30	10		
NW Willow Court		7	20		25	8		
Woodbury @ Cedar Court		30			85	28		
Public Works Site							225	
Totals		2604	11466	996	2260	705	625	852

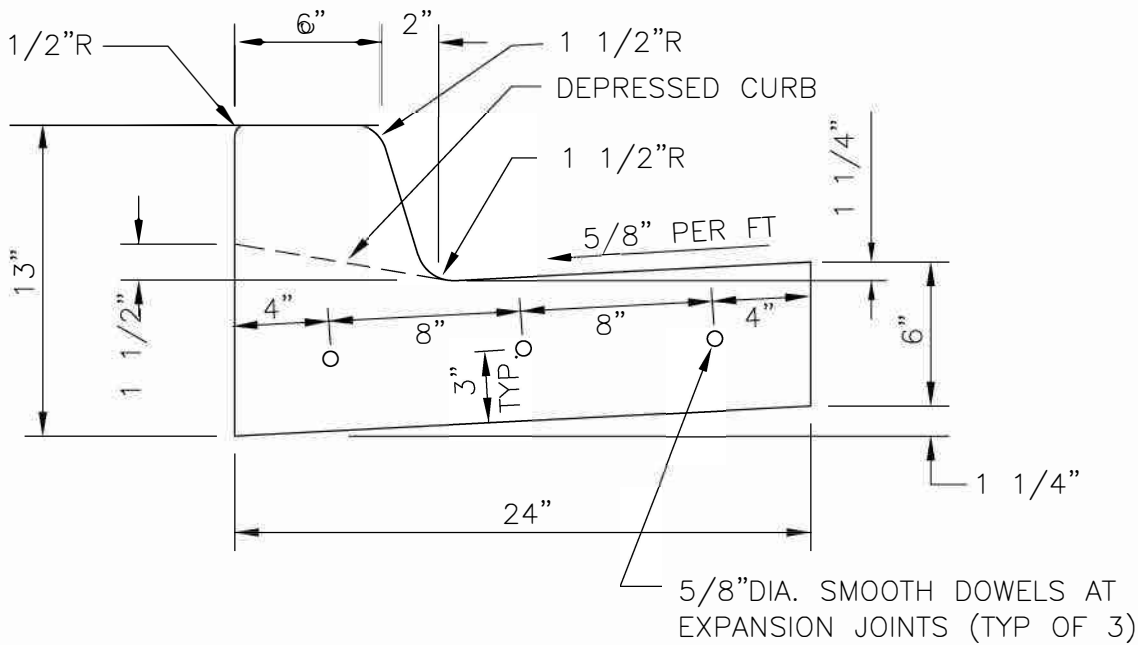

CROSS SECTION

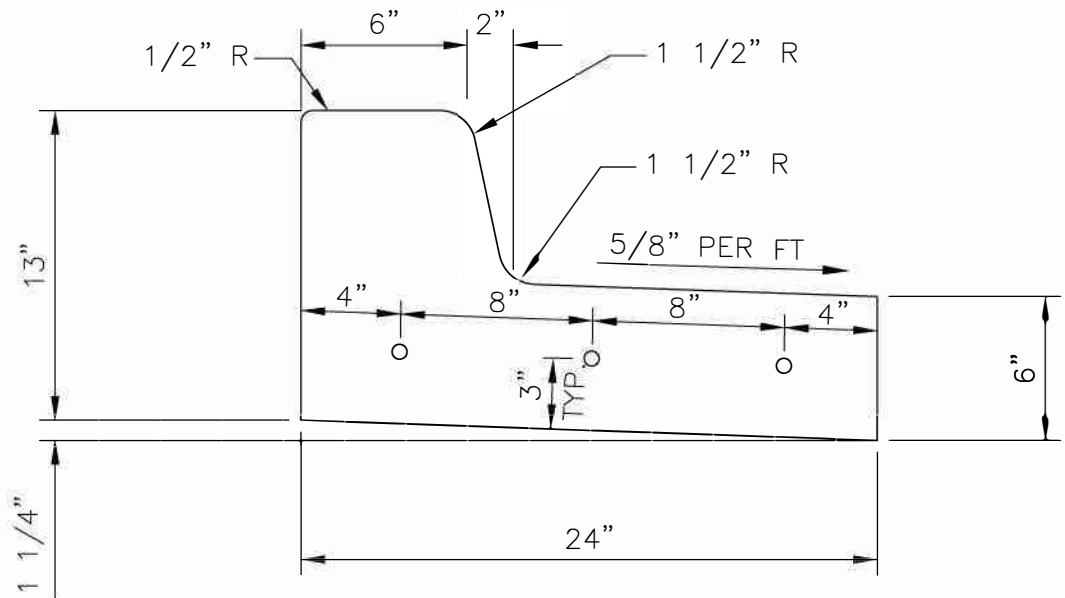

CROSS SECTION

NOTES:

(DRY CURB)

1. 3/4" EXPANSION JOINTS WITH 3-#5 X 2' DOWELS TO BE PLACED AT THE RADIUS POINTS AND NOT MORE THAN 100 FEET APART ON STRAIGHT RUNS. THESE DOWELS SHALL BE GREASED AND WRAPPED ON END WITH EXPANSION TUBES.
2. 1 1/2" DEEP CONTRACTION JOINTS SHALL BE INSTALLED AT APPROXIMATELY 15' INTERVALS. THESE JOINTS SHALL PASS THROUGH THE ENTIRE CURB SECTION SURFACE.
3. ALL CONCRETE CONSTRUCTION TO BE KCMMB4K.

TYPICAL BARRIER CURB AND GUTTER

APWA TYPE CG-1



DATE: 04/28/20
SCALE: NO SCALE

STR-005

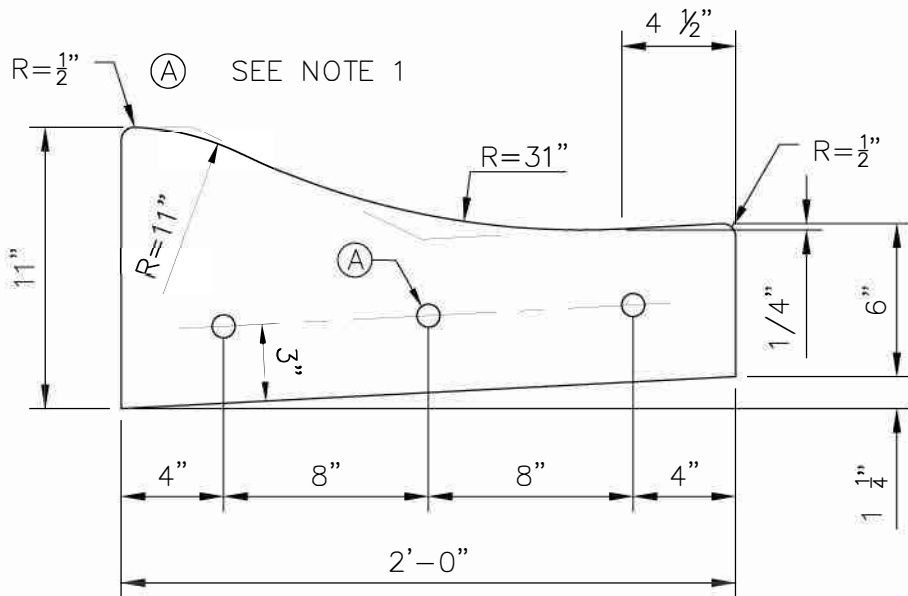

CROSS SECTION

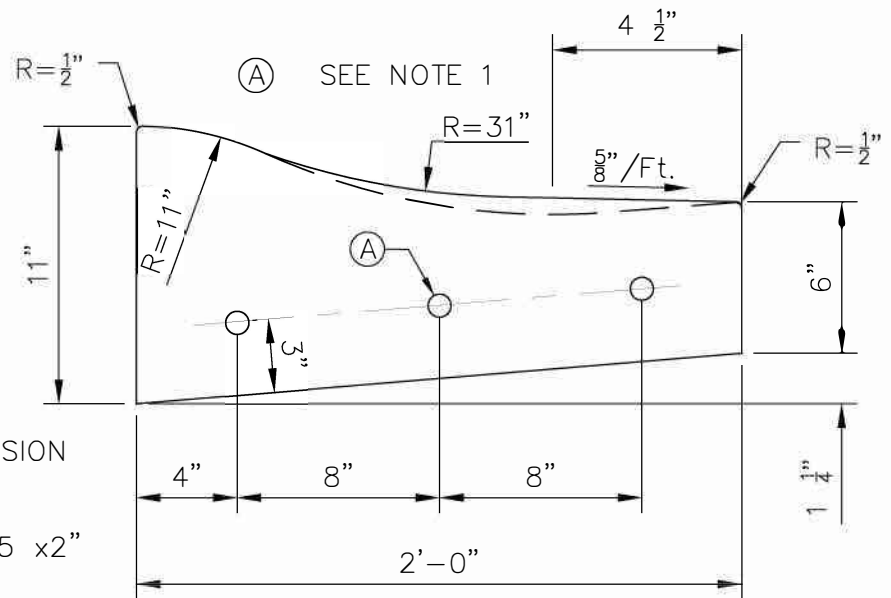

CROSS SECTION
(DRY CURB)

NOTES:

1. 5/8" DIA. SMOOTH DOWELS AT EXPANSION JOINTS (TYP. OF 3)
2. 3/4" EXPANSION JOINTS WITH 3 - #5 x 2" DOWELS TO BE PLACED AT RADIUS POINTS AND NOT MORE THAN 100' APART. THESE DOWELS SHALL BE GREASED AND WRAPPED ON END WITH EXPANSION TUBES.
3. 1 1/2" DEEP CONTRACTION JOINTS SHALL BE INSTALLED AT APPROXIMATELY 15' INTERVALS THESE JOINTS SHALL PASS THROUGH THE ENTIRE CURB SECTION SURFACE.
4. ALL CONCRETE CONSTRUCTION SHALL BE KCMMB4K

TYPICAL ROLL BACK CURB AND GUTTER

APWA TYPE CG-2



DATE:	04/28/20
SCALE:	NO SCALE

STR-006

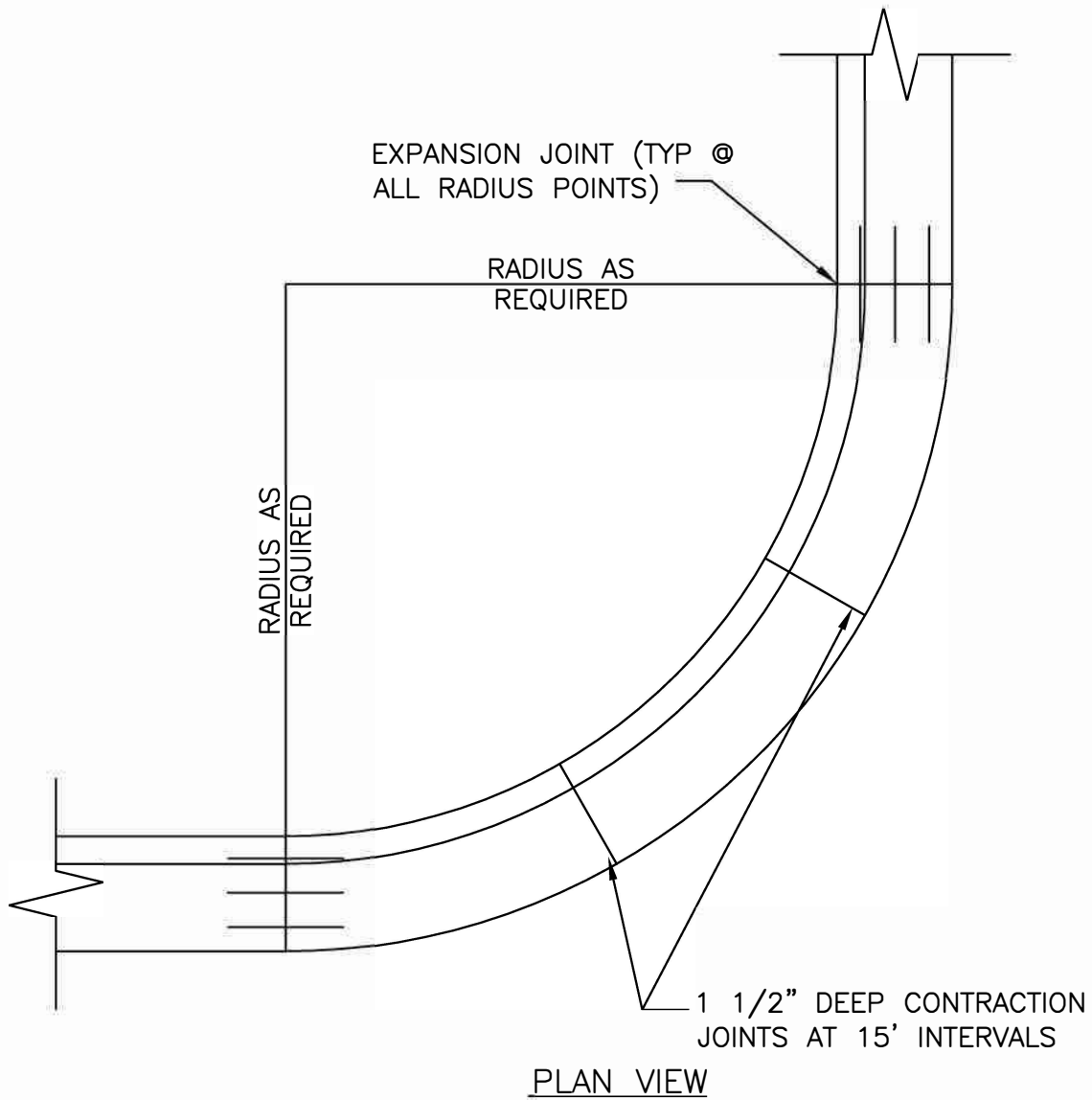

RADIUS	= FT
RESIDENTIAL	= 25'
RESIDENTIAL COLLECTOR	= 35'
INDUSTRIAL COLLECTOR	= 50'
COMMERCIAL COLLECTOR	= 30'
MINOR ARTERIAL	= 35'
MAJOR ARTERIAL	= 35'-50'

CURB EXPANSION JOINTS

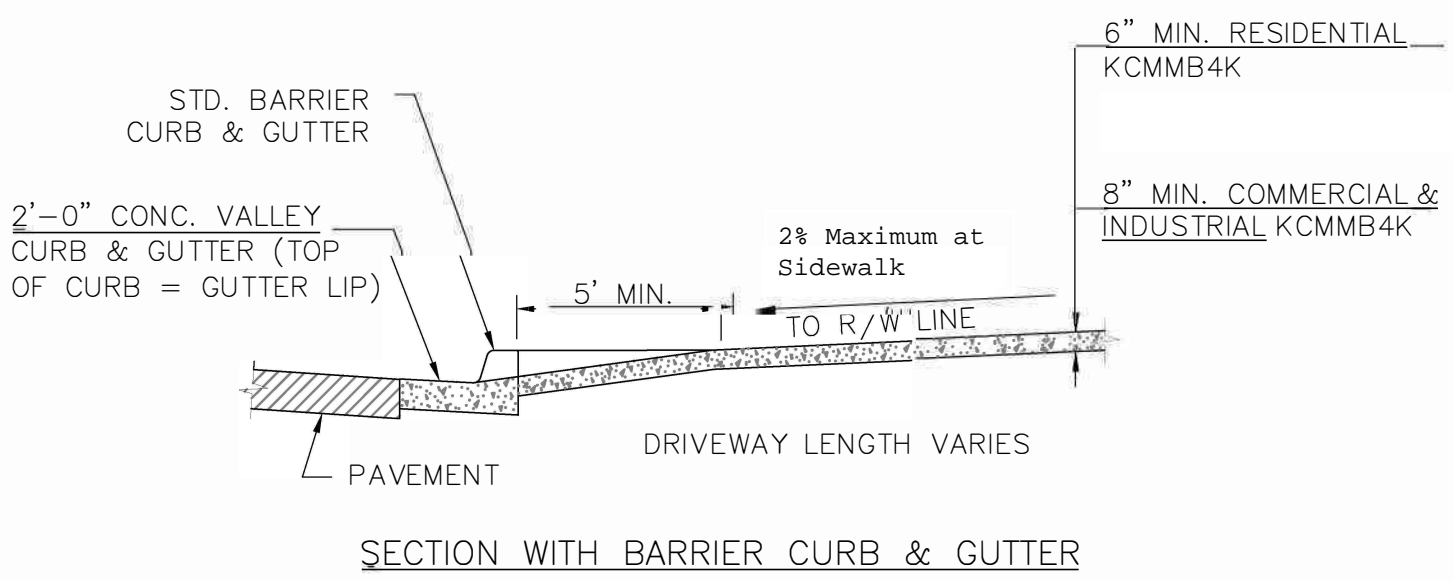
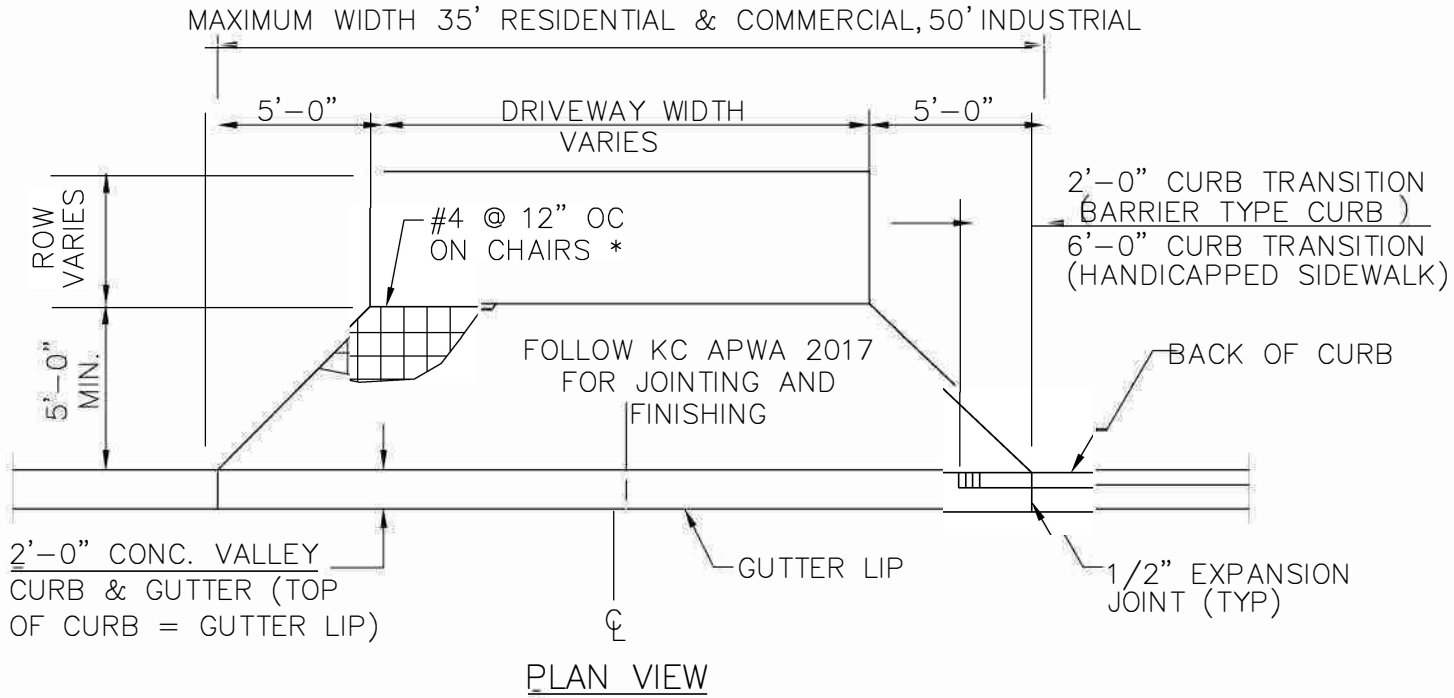

DRIVEWAY DETAIL WITH CURB TRANSITION (TYPICAL)



DATE:	04/28/20
SCALE:	NO SCALE

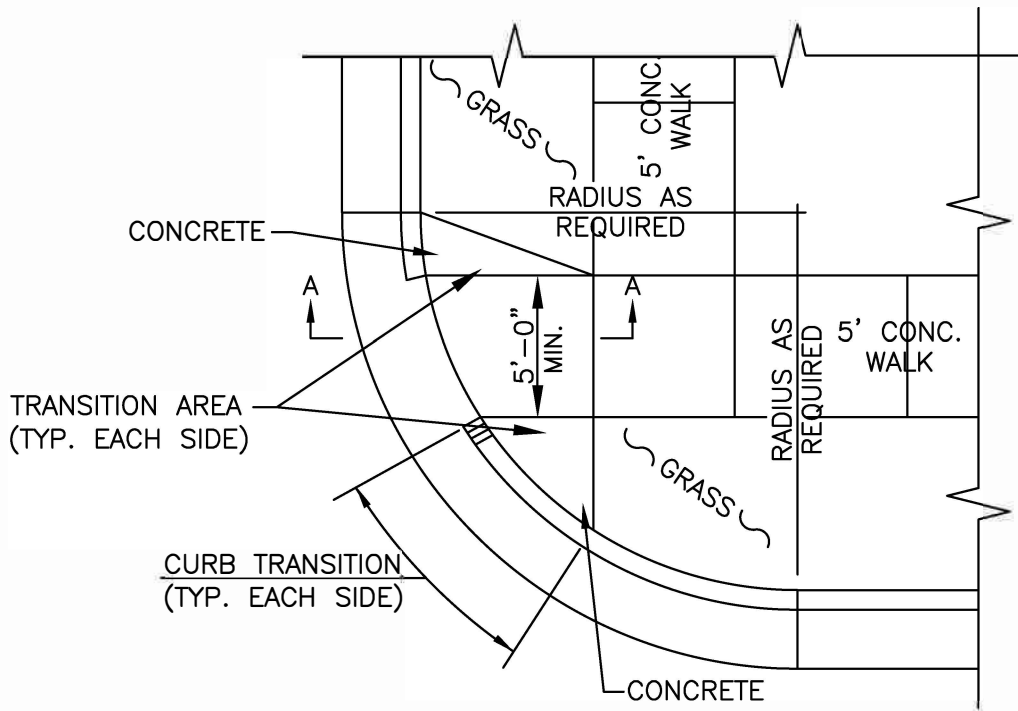

PLAN VIEW

NOTE: RAMP & TRANSITION AREA SHALL HAVE A BROOM SURFACE FINISH

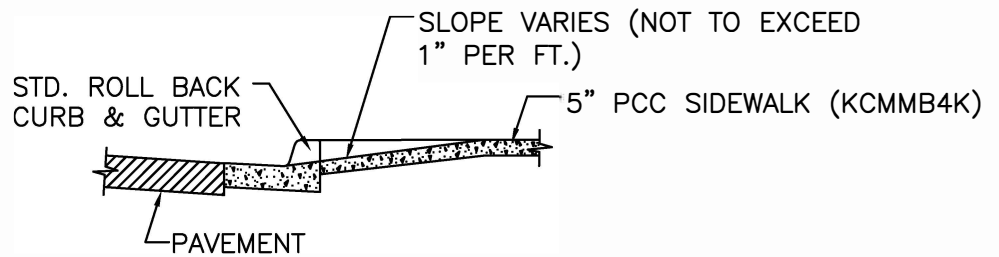

SECTION A-A WITH BARRIER CURB & GUTTER

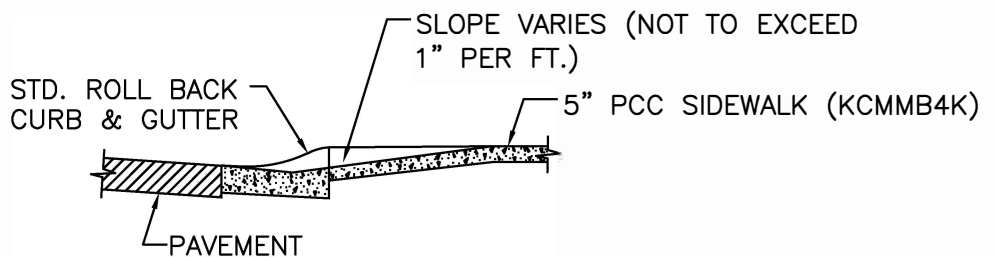

SECTION A-A WITH ROLL BACK CURB & GUTTER

WHEEL CHAIR RAMP "B" DETAIL

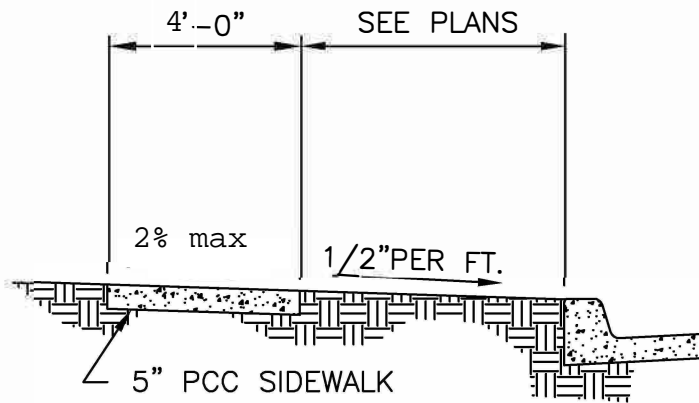

TYPICAL SIDEWALK SECTION

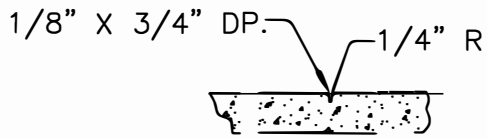

CONTRACTION JOINT

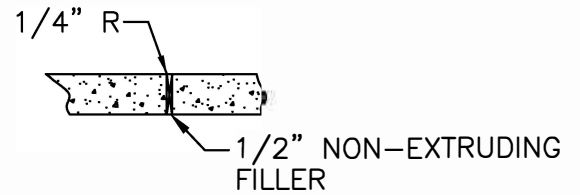

EXPANSION JOINT

NOTES:

1. CONTRACTION JOINTS 5' O.C. OR WIDTH OF SIDEWALK.
2. EXPANSION JOINTS SHALL ABUT EX. WALKS, CURBS, DRIVEWAYS, SIMILAR STRUCTURES AND 250' CTRS. MAXIMUM.
3. KEY ALL CONSTRUCTION JOINTS.

SIDEWALK DETAIL

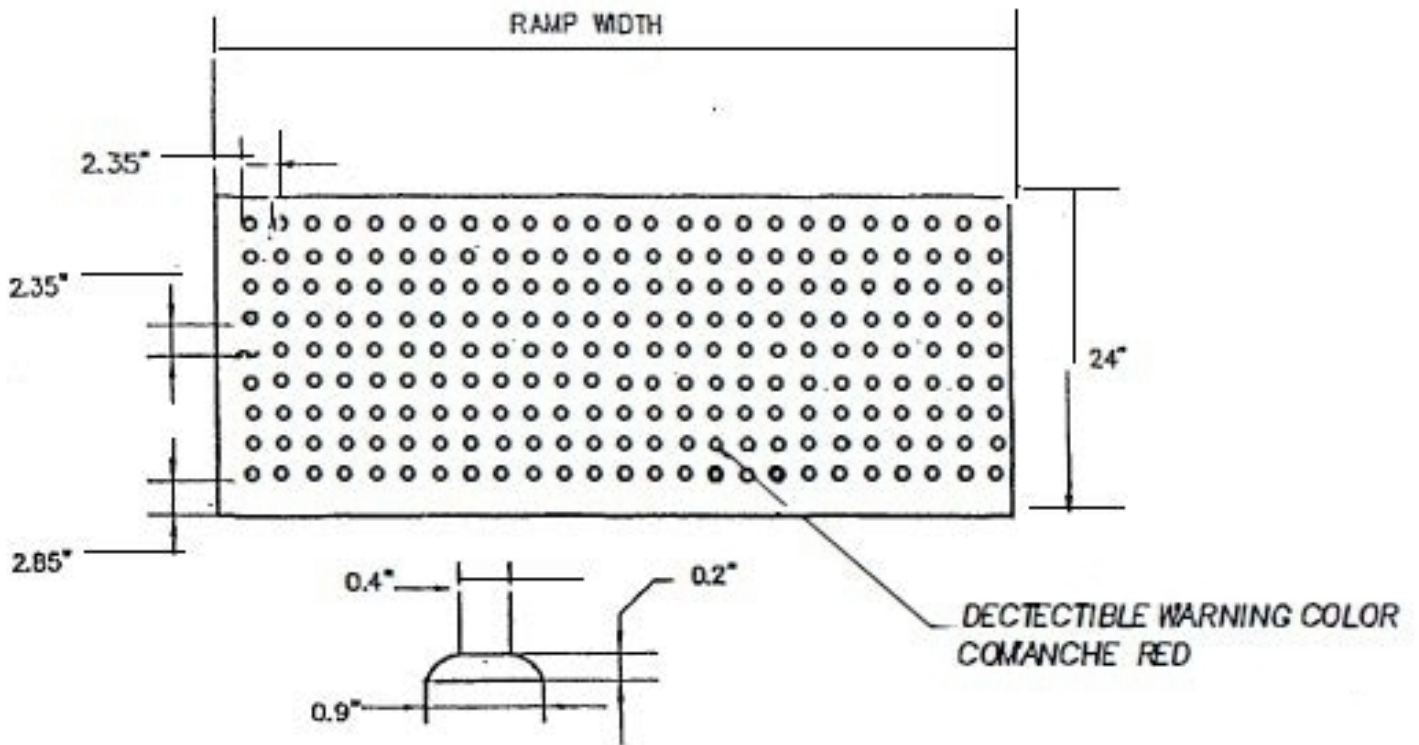

1108.1.1 Dome Size. Truncated domes in a detectable warning surface shall have a base diameter of 0.9 inches (23 mm) minimum to 1.4 inches (36 mm) maximum, a top diameter of 50% of the base diameter minimum to 65% of the base diameter maximum, and a height of 0.2 inches (5 mm).

ALL CURB RAMPS SHALL BE CONSTRUCTED WITH RAISED TRUNCATED DOME DETECTABLE WARNINGS.

SIDEWALK DETECTIBLE WARNING DETAIL